

**IN THE UNITED STATES DISTRICT COURT
FOR THE MIDDLE DISTRICT OF TENNESSEE**

SCOTT YOUNG, individually and on behalf of
others similarly situated,

Plaintiff,

vs.

NISSAN NORTH AMERICA, INC., a Delaware
corporation,

Defendants.

Civ. No.: _____

CLASS ACTION COMPLAINT

JURY TRIAL DEMANDED

Plaintiff Scott Young (“Plaintiff”) brings this action against Defendant Nissan North America, Inc. (“Defendant” or “Nissan”), by and through his attorneys, individually and behalf of all others similarly situated, and allege as follows:

INTRODUCTION

1. This is a class action lawsuit brought by Plaintiff on behalf of himself and a class of current and former Nissan vehicle owners and lessees of model years (“MY”) 2021-2023 Nissan Rogue vehicles equipped with Nissan’s Direct Injection Gasoline (“DIG”) engines (the “Class Vehicles” or “Vehicles”).¹

2. This action arises from Nissan’s failure, despite its longstanding knowledge of the material and manufacturing defect alleged herein, to disclose to Plaintiff and other consumers that the Class Vehicles are predisposed to an engine defect that causes fuel contamination of the engine oil, resulting in oil dilution, decreased oil viscosity, premature wear and ultimate failure of the engines, engine bearings and other internal engine components and an increased cost of

¹ Plaintiff reserves the right to amend or add to the vehicle models included in the definition of Class Vehicles after conducting discovery.

maintenance (the “Engine Defect”).² Such premature failures can also result in strong, overbearing gasoline smells and vapors within the vehicle cabin while driving, as well as in the vicinity of the exterior of the vehicle both while driving and when the vehicles are parked.

3. Significantly, and as a result of the Engine Defect, the engine oil within the Class Vehicles will lose its original viscosity, meaning the lubricating properties of the engine oil diminish and become less capable of withstanding the higher loads of an internal combustion engine. This can result in contact between metal surfaces within the engine, leading to rapid wear of internal bearings, the rotating assembly and other internal parts that rely on lubrication to function correctly.

4. Not only did Nissan actively conceal the fact that the Class Vehicles’ engines were defective (and require costly repairs to fix), it did not reveal that the existence of this Engine Defect would diminish the intrinsic and resale value of the Class Vehicles.

5. Nissan has long been aware of the Engine Defect, but despite that longstanding knowledge, it has failed to adequately repair the Class Vehicles when the Engine Defect manifests.

6. Many owners and lessees of Class Vehicles have communicated with Nissan and their agents to request that Nissan remedy and/or address the Engine Defect and resultant damage at no expense. Nissan has failed and/or refused to do so – often conveying to Vehicle owners and lessees that Class Vehicles are operating as intended and/or that Nissan does not have a fix for the Engine Defect such that they cannot be repaired under warranty or otherwise.

7. For customers whose Vehicles are within the Powertrain Limited Warranty period (which extends for the shorter of five years or 60,000 miles), Nissan has done nothing to address

² Plaintiff reserves the right to amend or add to the scope, nature, severity, and all other characteristics of the Defect after conducting discovery.

or correct the Engine Defect when it manifests in the Class Vehicles. Instead, Nissan has blamed Class members for not driving the Class Vehicles for longer distances and/or admitted that it is incapable of fixing the Engine Defect.

8. Despite notice and knowledge of the Engine Defect from the numerous consumer complaints it has received, information received from Nissan dealerships, pre-sale durability testing, National Highway Traffic Safety Administration (“NHTSA”) complaints, and its own internal records, Nissan has not recalled the Class Vehicles to repair the Engine Defect, offered its customers a suitable repair or replacement free of charge, or offered to reimburse its customers who have incurred out-of-pocket expenses to repair the Engine Defect.

9. As a result of Nissan’s unfair, deceptive and/or fraudulent business practices, owners and/or lessees of Class Vehicles, including Plaintiff, have suffered an ascertainable loss of money and/or property and/or loss in value. The unfair and deceptive trade practices committed by Nissan were conducted in a manner giving rise to substantial aggravating circumstances.

10. Had Plaintiff and other Class members known about the Engine Defect at the time of purchase or lease, they would not have purchased or leased the Class Vehicles, or would have paid substantially less for the Class Vehicles.

11. As a result of the Engine Defect and the considerable monetary costs associated with attempting to repair such defect, Plaintiff and class members have suffered injury in fact, incurred damages and have otherwise been harmed by Nissan’s conduct.

12. Accordingly, Plaintiff brings this action to redress Nissan’s violations of the Magnuson-Moss Warranty Act and the New Jersey Consumer Fraud Act, N.J. Stat. Ann. §§ 56:8-1, *et seq.*, and also to seek recovery for Nissan’s breach of express warranty, breach of implied warranty, fraud/fraudulent concealment, negligent misrepresentation, and, alternatively, unjust

enrichment.

JURISDICTION AND VENUE

13. This Court has subject matter jurisdiction over this action pursuant to 28 U.S.C. §1332 of the Class Action Fairness Act of 2005 because: (i) there are 100 or more class members, (ii) there is an aggregate amount in controversy exceeding \$5,000,000, exclusive of interest and costs, and (iii) there is minimal diversity because at least one plaintiff and one defendant are citizens of different states. This Court has supplemental jurisdiction over the state law claims pursuant to 28 U.S.C. § 1367.

14. This Court has personal jurisdiction over Nissan because it maintains its headquarters and principal place of business in Franklin, Tennessee, and is therefore a resident and citizen of this district, it has conducted substantial business in this judicial district, and intentionally and purposefully placed Class Vehicles into the stream of commerce within this district and throughout the United States.

15. Venue is proper in this judicial district pursuant to 28 U.S.C. §1391 because Nissan maintains its headquarters and principal place of business in Franklin, Tennessee, which is located in this district, transacts business in this district, is subject to personal jurisdiction in this district, and therefore is deemed to be a citizen and resident of this district. Additionally, Nissan has advertised in this district and has received substantial revenue and profits from its sales and/or leases of Class Vehicles in this district; therefore, a substantial part of the events and/or omissions giving rise to the claims occurred, in part, within this district.

THE PARTIES

Plaintiff Scott Young

16. Plaintiff Scott Young is a citizen of the State of New Jersey and resides in Barnegat, New Jersey.

17. In or around May 2022, Plaintiff bought a new 2022 Nissan Rogue from Nissan City of Red Bank, an authorized Nissan dealer and repair center located in in Red Bank, New Jersey.

18. Plaintiff purchased (and still owns) this vehicle, which is used for personal, family and/or household uses. His vehicle bears Vehicle Identification Number 5N1BT3BB3NC698878.

19. Within the first several months of owning the vehicle, Plaintiff began to smell a very strong scent of fuel in the vehicle cabin. When Plaintiff parks his vehicle in his driveway, he can smell a very strong scent of fuel around the exterior vicinity of the vehicle.

20. Plaintiff has his vehicle serviced approximately every 5,000 miles and the dealership has not found the source of the fuel smell during any of those services.

21. Plaintiff has suffered an ascertainable loss as a result of Defendant's omissions and/or misrepresentations associated with the Engine Defect, including, but not limited to, future attempted repairs and out of pocket losses, and diminished value of his vehicle.

22. Neither Defendant, nor its agents, agents, dealers or other representatives informed Plaintiff of the existence of the Engine Defect prior to purchase. Had Defendant disclosed the Engine Defect prior to Plaintiff's purchase, Plaintiff would not have purchased the vehicle, or would have paid substantially less for it.

Defendant Nissan North America, Inc.

23. Defendant Nissan North America, Inc. ("Nissan") is and was a company organized and existing under the laws of Delaware, having a principal place of business in this district at 1 Nissan Way, Franklin, TN 37067-6367. Defendant Nissan regularly conducts and transacts business in this jurisdiction and throughout all fifty U.S. states, either itself or through one or more subsidiaries, affiliates, business divisions, or business units.

24. Nissan, through its various entities, designs, manufactures, markets, distributes, sells, and leases Nissan automobiles in this district and multiple other locations in the United States. Nissan, and/or its agents and subsidiaries, designed, manufactured, distributed, offered for sale, sold, and installed the engine systems in the Class Vehicles. Nissan also developed and disseminated the materially misrepresentative owners' manuals, warranty booklets, product brochures, advertisements, and other intentionally unreasonable and deceptive promotional materials relating to the Class Vehicles, with the intent that such documents be purposely distributed throughout all fifty states. Nissan is engaged in interstate commerce, selling vehicles through its network in every state of the United States.

25. Nissan-authorized automobile dealerships act as Nissan's agents in selling automobiles under the Nissan name and disseminating vehicle information provided by Nissan to customers. At all relevant times, Nissan's dealerships served as its agents for motor vehicle repairs and warranty issues because they performed repairs, replacements, and adjustments covered by Nissan's manufacturer warranty pursuant to the contracts between Nissan and its 1,000+ authorized dealerships nationwide.

TOLLING OF STATUTES OF LIMITATION

26. Any applicable statute(s) of limitations has been tolled by Nissan's knowing and active concealment and denial of the facts alleged herein. Plaintiff and members of the Class could not have reasonably discovered the true, latent defective nature of the Engine Defect until shortly before this class action litigation was commenced.

27. Nissan was and remains under a continuing duty to disclose to Plaintiff and members of the Class the true character, quality and nature of the Class Vehicles and that it will require costly repairs and diminishes the resale value of the Class Vehicles. As a result of the active

concealment by Nissan, any and all applicable statutes of limitations otherwise applicable to the allegations herein have been tolled.

FACTUAL ALLEGATIONS

A. The Engine Defect within the Class Vehicles

28. Nissan began developing DIG engines in the late-2000's, with the goal of decreasing fuel consumption and improving fuel efficiency in its vehicles.³

29. Since then, Nissan has manufactured multiple Nissan and Infiniti branded vehicles with DIG engines, including but not limited to the following model years sold and distributed by Nissan in the U.S.:

- KR15DDT – 1.5L DIG engine
 - Nissan Rogue: 2021-present
- PR25DD – 2.5L DIG engine
 - Nissan Altima 6 (L34) in 2018-present
 - Nissan Rogue 3 (T33) in 2021-present
- MR20DD - 2.0L DIG engine
 - Nissan Rogue Sport: 2017-present
 - Nissan Sentra: 2020-present
- MR16DDT – 1.6L DIG turbo engine
 - Nissan Juke: 2011-present
 - Nissan Sentra SR Turbo & NISMO: 2017-present
- VR30DDTT – DIG engine
 - Infiniti Q50: 2016-present
 - Infiniti Q60: 2017-present
 - Nissan Z: 2022-present
- HR12DDT - 1.2L DIG turbo engine
 - Nissan Juke I: 2014–2018
- HR10DDT - 1.0L DIG turbo engine
 - Nissan Juke II: 2019

³ <https://www.greencarcongress.com/2010/07/nissan-unveils-new-3cylinder-12l-supercharged-gasoline-direct-injection-engine-targeting-lowest-fuel.html> (last visited April 21, 2023).

- VQ35DD – 3.5L DIG engine
 - Nissan Pathfinder: 2017-present
 - Nissan Infiniti QX60: 2017-present

- VQ38DD – 3.8L DIG engine
 - Nissan Frontier: 2020-present

- VK56VD – 5.6L DIG engine
 - Infiniti QX80: 2011-present
 - Infiniti M56: 2011-13
 - Infiniti Q70: 2014-19
 - Nissan NV2500 HD: 2017-present
 - Nissan NV3500 HD: 2017-present
 - Nissan NV Passenger: 2017-present
 - Nissan Titan: 2017-present
 - Nissan Armada: 2017-present

30. The Nissan Rogue was introduced in the United States in 2007. Nissan first released a DIG engine in a Rogue model with its introduction of the 2017 Nissan Rogue Sport’s 2.0L MR20DD DIG engine. Nissan eventually converted all Rogue models to DIG engines in 2021 by releasing the KR15DDT 1.5L and PR25DD 2.5L DIG engines.

31. Nissan designed its GID engines—such as the KR15DDT 1.5L engine contained in MY2021-present Rogue models—to increase fuel efficiency.⁴ The below picture depicts the KR15DDT 1.5L engine contained in MY2021-present Rogue Class Vehicles:

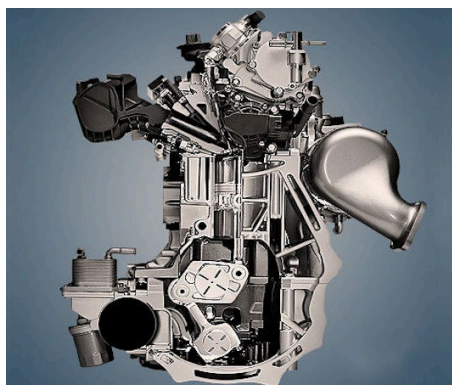

⁴ caranddriver.com/news/a35831603/2022-nissan-rogue-new-turbo-engine-revealed/ (last visited April 21, 2023).

32. One of the ways Nissan seeks to increase fuel economy in Class Vehicles is through its Variable Compression Engine (“VCE”) technology that allows the engines to alter the compression ration from 8:1 (providing more vehicle power and less fuel efficiency) to 14:1 (providing less power and more fuel efficiency).⁵ Specifically, the VCE engines contain a unique linkage in the crankcase that adjusts the piston stroke by just a few millimeters, which alters the compression ratio. The image below shows how the crankcase linkage rotates right to decrease the compression ratio and increase power when the driver presses down on the accelerator and wants to drive fast⁶:

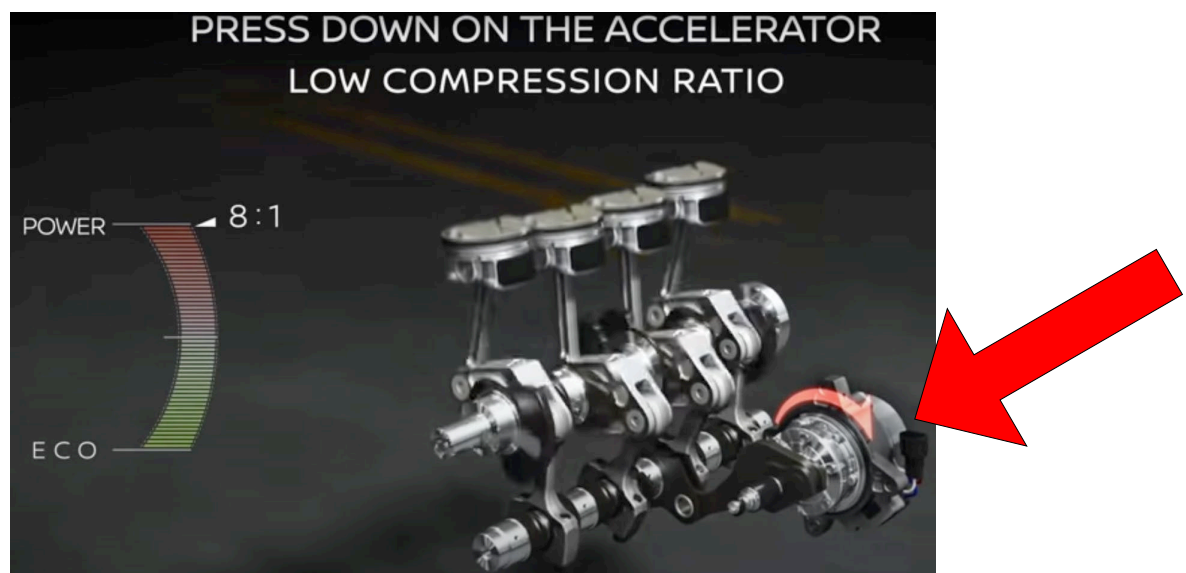

whereas the image below shows how the crankcase linkage rotates left to increase engine compression and increase fuel consumption when the driver eases-up on the accelerator to drive slower⁷:

⁵ <https://www.thedrive.com/news/43177/2022-nissan-rogue-gets-three-cylinder-variable-compression-turbo-engine> (last visited April 21, 2023).

⁶ <https://www.youtube.com/watch?v=j0An3RbXcPg&t=96s> (last visited April 21, 2023).

⁷ *Id.*

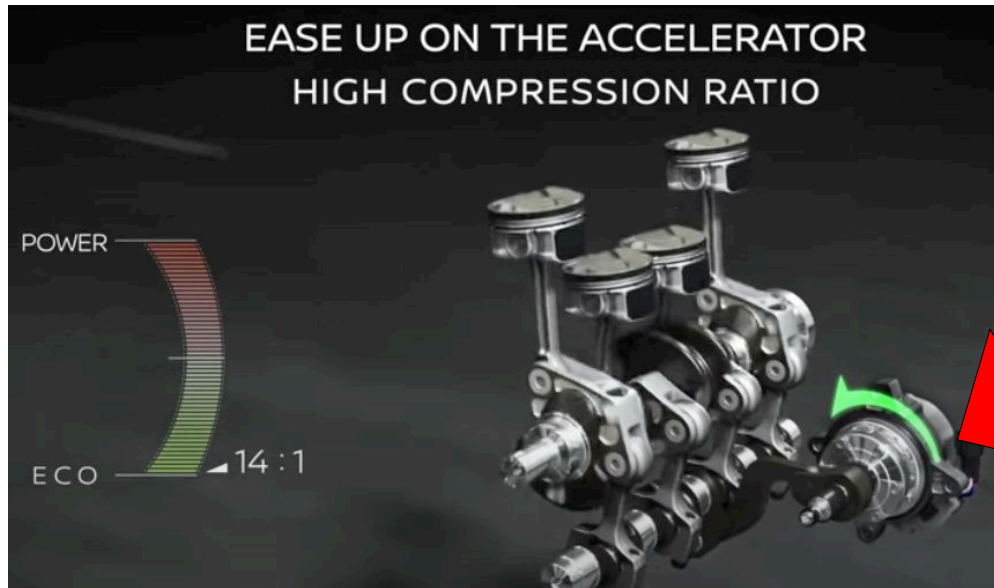

The two images below provide a closeup view of how the crankcase linkage moves left and right in these two alternate extremes to alter the length of the piston stroke (and, in turn, the compression ratio), the first image showing the “eco” setting to increase fuel economy, and the second image showing the “power” setting to increase vehicle power⁸:



⁸ *Id.*



Thus, by changing the position of the crankcase linkage, Nissan's VCE engines alter the compression ratio to increase/decrease fuel economy⁹:

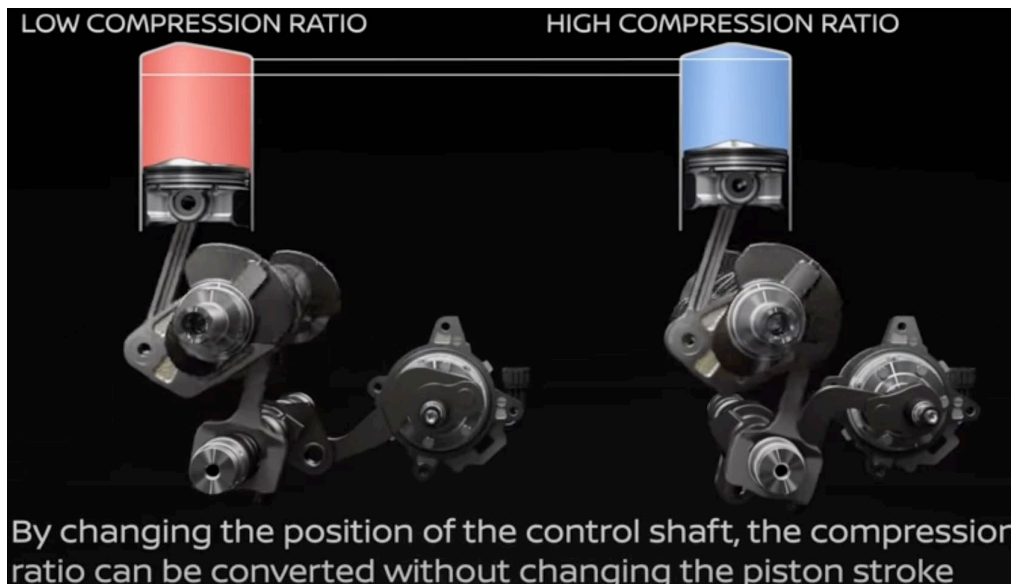

33. The foregoing images depict the Class Vehicles' use of reciprocating pistons to convert pressure into a rotating motion, to drive the vehicle. Specifically, gasoline is mixed with air in the combustion chambers of the engine. To generate such rotating motion, a four-step sequence is used (the "Combustion Cycle"). First, the intake stroke begins with the inlet valve opening and a vaporized fuel mixture is pulled into the combustion chamber (the "Intake Stroke").

⁹ *Id.*

Second, the inlet valve closes and the piston begins its movement upward, compressing the fuel mixture in the combustion chamber (the “Compression Stroke”). Third, the power stroke begins when the spark plug ignites the fuel mixture, expanding the gases and generating power that is transmitted to the crankshaft (the “Power Stroke”). And fourth, the exhaust stroke begins with the exhaust valve opening and the piston moving back up, forcing the exhaust gases out of the cylinder (the “Exhaust Stroke”). The exhaust valve then closes, the inlet valve opens, and the Combustion Cycle repeats itself. A diagram of a Combustion Cycle and all four strokes therein is below:

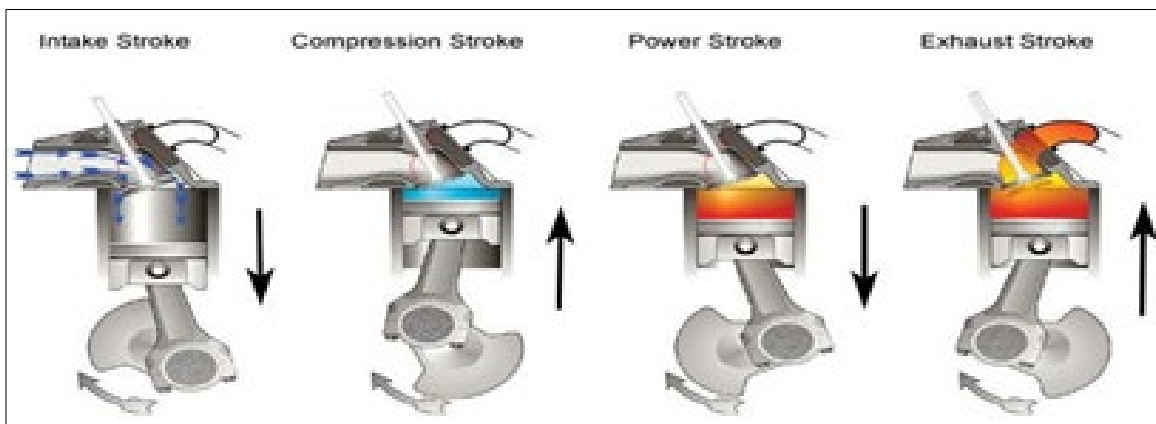

34. The engines in the Class Vehicles utilize fuel injectors mounted on the cylinder head, rather than on the intake manifold as in traditional engine applications. This fuel delivery method in the Class Vehicles is known as Direct Injection Gasoline (DIG) whereby fuel is injected at a very high pressure directly into the combustion chamber rather than through the intake manifold.

35. Because of the high fuel pressures required for the DIG system in the Class Vehicles, some of the fuel injected into the combustion chamber remains unburned. The unburned mixture of air and gasoline is then pulled down by the piston, slipping by the piston and oil control rings, and goes directly into the crankcase, which is the protective cover that insulates the crankshaft. This is commonly referred to as “blow-by” and it is undesirable because the unburned

gasoline in the mixture enters the engine's crankcase and can significantly contaminate the engine oil contained in the oil pan. Once blow-by occurs, the fuel dilutes the lubricity and viscosity of the engine oil, attacking engine bearings, the valve train, fuel injectors and cylinder walls. One tell-tale sign of blow-by occurrence is the smell of that unburned, raw gasoline in the vehicle cabin and in the vicinity of the exterior of the vehicle, such as that experienced by Plaintiff and alleged herein. Additionally, the oil dilution will cause the oil level in the crankcase of the Class Vehicles to increase.

36. To reduce the risk of crankcase contamination and improve vehicle emissions, the positive crankshaft ventilation ("PCV") system was invented in the early 1960s. The PCV system involves the recycling of these unwanted gases through a valve (the "PCV valve") and circulates them back into the intake manifold, where they are pumped back into the cylinders for another chance at being burned during the combustion cycle. A diagram of a typical PCV system is below:

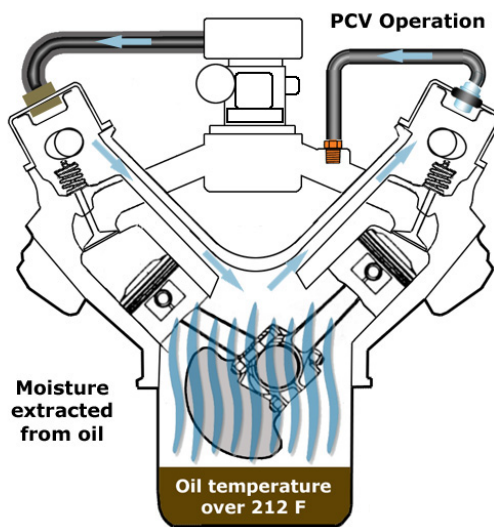

37. In the Class Vehicles, the PCV system is simply inadequate to prevent and address fuel contamination of the crankcase. This is because the volume of unburned fuel contamination is so massive due to, *inter alia*, (1) the increased amount of unburned fuel in the combustion chamber due to the high fuel pressures of the DIG system; and (2) increased blow-by as a result

of the reduced piston and oil control ring tensions in an effort to decrease overall friction within the engine in the hopes of gaining greater miles per gallon (“MPG”).

38. In the Class Vehicles, the engine pistons are connected to the crankshaft via the connecting rods. As the connecting rods move up and down during the Combustion Cycle, this causes the crankshaft to rotate, ultimately resulting in power to the drive wheels of the vehicle. During this cycle, the crankshaft rotates many thousands of times per minute within each connecting rod. In order to reduce friction and prolong longevity, it utilizes a bearing placed between each connecting rod and multiple crankshaft surfaces. As a result, the connecting rod bearings allow the crankshaft to rotate within the connecting rods during the Combustion Cycle. An exemplar diagram of the piston, connecting rod, connecting rod bearing and crankshaft is shown below:

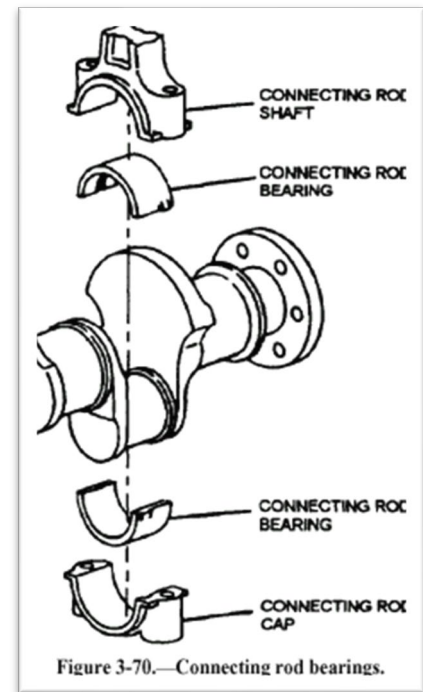
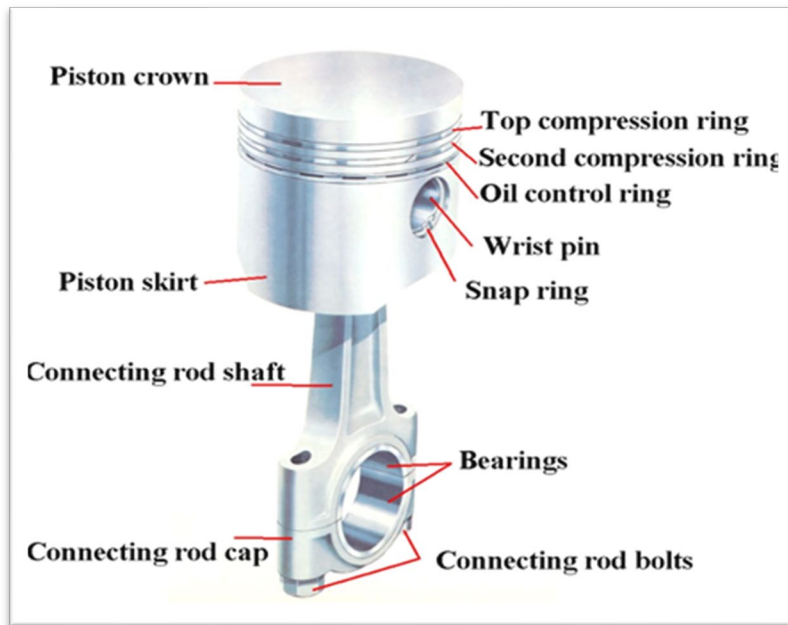

39. When the Class Vehicles are in operation, engine oil is used to lubricate the piston, cylinder wall, connecting rod bearings, main bearings and other rotating and moving components as the pistons move up and down through the four-stroke sequence. Engine oil is necessary to

reduce wear on the moving parts throughout the engine, to improve sealing, and to cool the engine by carrying away heat from the moving parts. Engine oil also cleans and transports contaminants away from the engine to the engine oil filter. Oil is pumped and pressurized throughout the engine by the oil pump. The oil pump draws oil from the oil pan, located underneath the pistons and crankshaft. The oil pump forces engine oil through the oil filter and then through passages in the engine to properly lubricate and reduce friction in internal moving engine components. The oil then returns to the oil pan through small drainage holes located throughout the engine where it will be recirculated by the oil pump. Below is a diagram illustrating the typical path and channels of engine oil lubrication in an overhead cam engine:

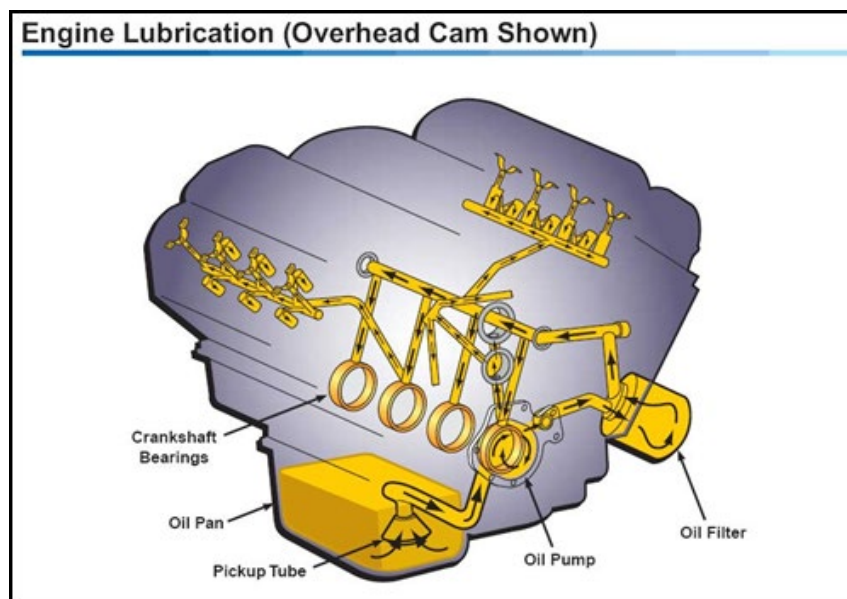

40. The Engine Defect inherent in the Class Vehicles results in the build-up of non-combusted fuel within the engine's oiling system. As the fuel builds up within the oiling system, the engine oil is diluted and begins to lose its lubricating properties. This fuel-contaminated engine oil no longer properly coats the bearing surfaces, compromising the integrity of the oil barrier between the bearings and the corresponding metal parts which they are designed to protect. When the Engine Defect manifests, it results excessive and frequent contact between the connecting rods

and connecting rod bearings, as well as the crankshaft and main bearings. This contact causes accelerated wear within the engine and on the bearing surfaces in the Class Vehicles.

41. Additionally, the Engine Defect causes the crankcase of the Class Vehicles to become overfilled with fuel-contaminated oil. As a result, the engine oil level can come in contact with the crankshaft. When this happens, engine oil is turned (or aerated) by the crankshaft thereby becoming oxygenated and of a foamy quality. This oxygenated oil mixture fails to lubricate effectively and will often result in overheating as well as damage to the engine's moving parts. In some cases, there may even be a loss of oil pressure since aerated oil can result in oil pump cavitation. Per the below diagrams from the Owner's Manual of a MY2021 Rogue Class Vehicle, Nissan is well aware that excessive oil in the crankcase will result in damage to the Class Vehicles:¹⁰

ENGINE OIL

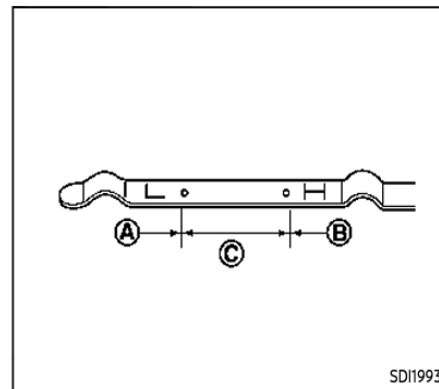

CHECKING ENGINE OIL LEVEL

1. Park the vehicle on a level surface and apply the parking brake.
2. Run the engine until it reaches operating temperature.
3. Turn off the engine. **Wait more than 10 minutes for the oil to drain back into the oil pan.**
4. Remove the dipstick and wipe it clean. Reinsert it all the way.
5. Remove the dipstick again and check the oil level. It should be within the range ©. If the oil level is below Ⓐ, remove the oil filler cap and pour recommended oil through the opening. **Do not overfill Ⓑ.**

¹⁰ <https://cdn.dealereprocess.org/cdn/servicemanuals/nissan/2021-rogue.pdf> (last visited April 21, 2023).

42. In addition, the Class Vehicles' Owner's Manuals warn: "Operating the vehicle with deteriorated oil can damage the engine."¹¹

43. Regardless of this known risk, Nissan instructs Class Members to continue to drive their Class Vehicles and ignore the fuel smell, put their windows down, and alter their HVAC settings to try to alleviate the smell. Once oil dilution occurs, many Class Vehicles will also require replacement of fouled spark plugs and even fuel injectors along with risk of camshaft, rocker-arm assembly, and engine damage. This results in a previously undisclosed increase in the cost of maintenance for Class members due to the Engine Defect. Additionally, this results in a greater impact on the environment due to the necessary and frequent disposal of contaminated engine oil due to the Engine Defect.

B. Nissan Advertises the Class Vehicles as Reliable, Safe, and Top Quality Despite its Knowledge of the Engine Defect

44. Despite widespread consumer complaints of strong fuel smell in Class Vehicles and other issues affiliated with the Engine Defect, Nissan has not acknowledged the existence of the Engine Defect in the Class Vehicles to Class Members.

45. Furthermore, Nissan's failure to notify the general public or the owners or lessees of the Class Vehicles of the Engine Defect is particularly egregious because after the Engine Defect manifests, the Class Vehicles not only suffer from strong fuel smell during vehicle use, but also may suffer catastrophic engine failure while in use, resulting in a very dangerous situation (and can even be left stranded) placing the driver and occupants at an increased risk of injury.

46. Engines are intended to function for periods (and mileages) substantially in excess of those specified in Nissan's warranties, and given past experience, consumers legitimately expect

¹¹ *Id.* at 2-29.

to enjoy the use of an automobile without worry that the engine will fail for significantly longer than the limited times and mileages identified in Nissan's warranties.

47. Indeed, Nissan markets its vehicles as safe and reliable, and emphasizes that its vehicles are quality and of the highest level of craftsmanship¹²:



48. Nissan promises consumers that it will listen to their feedback about Class Vehicles and be honest and transparent about them:¹³

¹² <https://www.nissan-global.com/EN/SUSTAINABILITY/SOCIAL/QUALITY/PRODUCTS/> (last visited April 21, 2023).

¹³ See, e.g., <https://www.nissanusa.com/about/nissan-customer-promise.html> (last visited April 21, 2023).

NISSAN

CUSTOMER PROMISE

Our promise is to respect your time and seamlessly deliver a personalized experience tailored to your needs



Our Commitment to You

- **We will communicate** honestly and transparently ensuring full understanding of all products and services to help you make confident buying decisions.
- **We employ knowledgeable** and professional staff that will help you understand technology, features and connect with your new vehicle.
- **We are listening** and will use your feedback to enhance future experiences.

49. Nissan touts its purported robust quality assurance processes on its website that “guarantees” the reliability and quality of its vehicles: “Nissan has established a unique system that guarantees reliable quality Ensuring quality is of utmost importance.”¹⁴

50. Nissan’s website ensures consumers that it conducts detailed quality checks of every vehicle¹⁵:

¹⁴ <https://www.nissan-global.com/EN/SUSTAINABILITY/SOCIAL/QUALITY/PRODUCTS/ASSURANCE/> (last visited April 21, 2023).

¹⁵ <https://www.nissan-global.com/EN/SUSTAINABILITY/SOCIAL/QUALITY/PRODUCTS/SYSTEM/> (last visited April 21, 2023).

Over 300 “customer’s-perspective” quality checks

How should we check vehicle quality from the customer’s perspective? Nissan’s answer to this question is the Alliance Vehicle Evaluation Standard (AVES). This system evaluates product quality according to more than 300 criteria developed from the customer’s perspective. These checks are rigorously conducted by Nissan staff certified in using the AVES system.

When checking the condition of body paint, for example, we envisage a situation where the customer is extremely close to the car’s exterior, such as when they are washing the car. We then keep this perspective in mind as we check for scratches and color irregularities.

51. Nissan touts that its vehicles are high quality and reliable because it conducts repeated test-drives to ensure that they are¹⁶:

Using test vehicles to imagine customer-use scenarios

In order to deliver high-quality cars to our customers, Nissan manufactures test vehicles that are repeatedly test-driven and trialed under the strictest conditions. The results of these trials guide us in raising quality to a level that exceeds customer performance expectations.

During these test drives, we carefully assess performance as cars drive, corner and stop in a variety of imagined customer use scenarios. We also adopt a customer perspective to evaluate advanced features that provide customers with added value, such as the latest driver assistance technology.

Nissan claims to perform routine quality assessments even after models are introduced into the stream of commerce and guarantees their quality: “Even after a vehicle enters mass production, the AVES system is periodically used to guarantee quality. This means that we are continually assessing quality from a customer perspective, which improves quality outcomes and contributes

¹⁶ *Id.*

to customer satisfaction.”¹⁷

52. Nissan’s website is replete with representations related to its purported processes for driving vehicles and performing various driving-performance tests and evaluations to ensure their reliability¹⁸:

Driving in locations around the world to refine quality for the benefit of our customers globally

There are four main phases to creating and supplying a vehicle: planning, development, production and marketing/sales. Our running tests are conducted during the two middle stages. We use a factory test car during development, and then a mass-production test car during production. We address the issues that emerge during the development stage immediately, before the car reaches the mass-production test car stage. We then confirm that the final quality standards have been met. The running tests performed during these two stages are all conducted in the regions where the vehicles will be marketed and sold. Meticulous efforts are made to ensure that Nissan vehicles suit local conditions.

Double-checking quality from data and driver feedback evaluation

We run rigorous, repetitive, high-precision tests over a short period, in some instances driving the cars for 24 consecutive hours or more. At Nissan, we refer to these systematized local running tests as PSQC* tests. Our test drivers conduct thorough checks on handling, drivability, engine noise and various other aspects from a critical perspective, evaluating all matters related to the customer’s driving experience. The data collected helps us to determine whether the vehicle meets the quality targets set.

* PSQC stands for Pre SOS Quality Clinic. This is Nissan’s original quality inspection system, which includes running tests conducted under the regional road and environmental conditions our customers will encounter.

¹⁷ *Id.*

¹⁸ <https://www.nissan-global.com/EN/SUSTAINABILITY/SOCIAL/QUALITY/PRODUCTS/GUARANTEE/> (last visited April 21, 2023).

Thoroughly refining quality to withstand both scorching heat and extreme cold

Virtual running tests are conducted to check quality under more severe conditions that are difficult to reproduce in a real environment. Our testing facilities and plants have environmental test chambers that can reproduce the heat, humidity and road conditions found in any region of the world. For example, vibration can be applied to simulate the rough, unpaved roads found in certain markets. We can evaluate the impact on the vehicle's handling or riding comfort and the deterioration of components from heat or humidity as well. At Nissan, actual and simulated running tests are repeated to ensure our customers can truly feel that Nissan vehicles are good vehicles. We strive to improve all-out quality.

53. Nissan's website states that it utilizes a detailed, rigorous, multi-faceted quality assurance process to ensure the reliability of its cars, including: "planning and development validation, turning design blueprints into prototypes, performance testing to the final mass production" which includes the following process¹⁹:

¹⁹ <https://www.nissan-global.com/EN/SUSTAINABILITY/SOCIAL/QUALITY/PRODUCTS/ASSURANCE/> (last visited April 21, 2023).

Nissan has created a system called ANPQP^{*1} for regulating the necessary quality assurance in this entire series of activities. The ANPQP requires tests to be carried out on every component from suppliers to ensure the delivery of high quality components from Nissan's suppliers.

*1 ANPQP stands for Alliance New Product Quality Procedure. Nissan created the ANPQP based on the standard for automotive sector quality management systems IATF16949, published by the International Automotive Task Force (IATF), to establish supplier quality assurance standards.

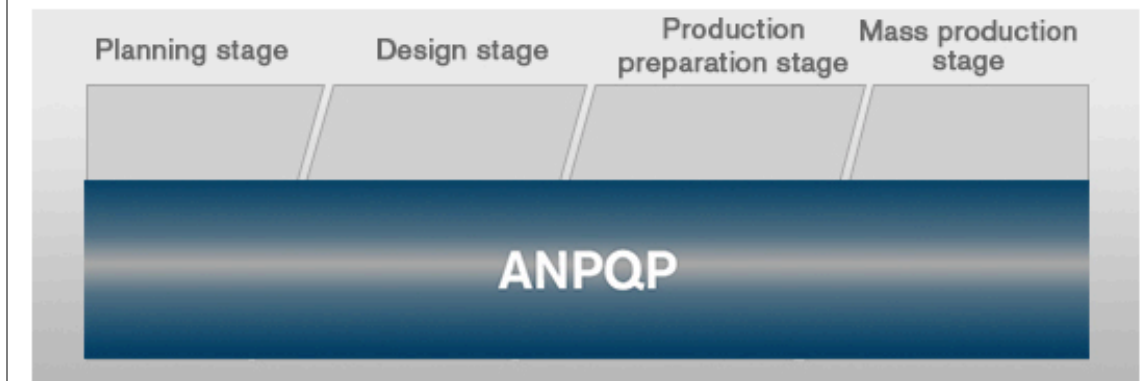

Thus, not only does Nissan's website represent that it monitors its own systems/processes for quality assurance, but that it also closely monitors its suppliers' processes as well²⁰:

²⁰ *Id.*

To address this issue, Nissan has developed a system called Alliance Supplier Evaluation Standard (ASES)*. With ASES, companies are evaluated on a five-level scale, classified as A, B, C, or D, and only those in the upper ranks are accepted as suppliers. Each supplier's actual work site is checked for 240 evaluation criteria, such as whether there is a system in place for clearly identifying non-defective or defective products, and what kind of systems are in place to prevent problems. ASES evaluations are conducted by specially trained evaluators who have passed rigorous tests. These activities lay the foundation for the delivery of accurate parts.

* ASES, the Alliance Supplier Evaluation Standard, is used to evaluate if a vendor qualifies to become a suitable supplier. Based on the evaluation of 240 criteria at five stages, we rank potential vendors as either A, B, C or D, and measure them against the top-ranked industry suppliers.

To maintain consistency in quality: Periodic supplier inspections

Alongside ANPQP, Nissan employs a system of checks to maintain quality assurance for suppliers. To visualize the delivery and market quality of suppliers with whom we already do business, we use Supplier Score Card. We also use the Supplier Health Check* system to monitor the health of plants at production sites. Combining these two systems ensures that our suppliers adhere to a system that consistently delivers superior components, and drives them to pursue continuous quality improvement.

*Supplier Health Check

In a constantly changing environment, the health of a plant may deteriorate and affect quality. Our Supplier Health Check system involves regularly diagnosing the health status of production sites to prevent deterioration in quality. We also implement new quality initiatives in response to changing conditions, including the introduction of remote confirmation from fiscal 2020.

54. Through these quality control metrics, Nissan knew or should have known that the engines in the Class Vehicles were defective.

55. Automobiles must be able to withstand foreseeable usage conditions. A vehicle can suffer extensive damage and costly repairs from customary environmental and usage conditions

when a vehicle suffers from a defect such as the Engine Defect. Indeed, as set forth above, Nissan states on its website that it tests in vehicles in the harshest of conditions, and puts them through repeated, rigorous cycles of testing, to ensure that they are able to withstand all foreseeable usage conditions, including the harshest such conditions.

56. In many instances, consumers have incurred and will continue to incur expenses for repair and/or replacement of the engines despite such Engine Defect having been contained in the Class Vehicles when manufactured by Nissan.

57. Upon information and belief, Nissan, through (1) its own records of customers' complaints, (2) dealership repair records, (3) records from the National Highway Traffic Safety Administration ("NHTSA"), (4) warranty and post-warranty claims, (5) internal pre-sale durability testing that Nissan touts on its website; and (6) other various sources, was well aware of the Engine Defect but failed to notify customers of the nature and extent of the problems with Class Vehicle engines or to provide any adequate remedy.

58. Despite the prodigious number of statements on Nissan's website about its presale testing processes, Nissan failed to adequately research, test and/or manufacture the engines and PCV systems in the Class Vehicles before warranting, advertising, promoting, marketing, and selling the Class Vehicles as suitable and safe for use in an intended and/or reasonably foreseeable manner.

59. Nissan is experienced in the manufacture of consumer vehicles. As an experienced manufacturer—and consistent with its website statements above—Nissan conducts tests, including pre-sale durability testing, on incoming components, including the engines, to verify that the parts are free from defect and align with Nissan's specifications. Thus, Nissan knew or should have known of the Engine Defect through its comprehensive quality assurance activities and

manufacturing controls.

60. Despite such assurances and procedures, Nissan has not contacted Class Members by direct mail or telephone to inform them how they can receive free repairs related to the Engine Defect within the United States. Additionally, upon information and belief, Nissan has also not provided associated information regarding the Engine Defect on its website or through the news media.

61. Per the below, Nissan also expressly warranted the Class Vehicles to be free from defects for a period of three years or 36,000 miles under the Limited Warranty and 5 years or 60,000 miles under the Powertrain Limited Warranty.²¹ Both warranties are applicable to the Engine Defect; however, Nissan has failed to correct the issue:

²¹ <https://www.nissanusa.com/content/dam/Nissan/us/manuals-and-guides/shared/2021/2021-nissan-warranty-booklet.pdf> (last visited April 21, 2023).

THE WARRANTY BEGINS

The warranty period begins on the date the vehicle is delivered to the first retail buyer or put into use, whichever is earlier.

FOR HOW LONG AND WHAT IS COVERED**■ BASIC COVERAGE**

- The basic coverage period is 36 months or 36,000 miles, whichever comes first.
- This warranty covers any repairs needed to correct defects in materials or workmanship of all parts and components of each new Nissan vehicle supplied by Nissan subject to the exclusions listed under the heading "WHAT IS NOT COVERED" or, if the part is covered by one of the separate coverages described in the following sections of this warranty, that specific coverage applies instead of the basic coverage.
- Bedliners will be repaired to commercially acceptable standards subject to the conditions and limitations listed in "WHAT IS NOT COVERED". SUPPLEMENTAL RESTRAINT SYSTEM (SRS).

■ POWERTRAIN COVERAGE

- The Powertrain coverage period is 60 months or 60,000 miles, whichever comes first.
- This warranty covers any repairs needed to correct defects in materials or workmanship.
- Powertrain coverage applies to components listed below under the headings Engine, Transmission and Transaxle, Drivetrain, and Restraint System, supplied by Nissan subject to the exclusions listed under the heading "WHAT IS NOT COVERED".

ENGINE

Cylinder heads and block and all internal parts, rocker covers and oil pan, valve train and front cover, timing chain and tensioner, oil pump, water pump and fuel pump, fuel injectors, intake and exhaust manifolds and turbocharger, flywheel, seals, and gaskets.

TRANSMISSION AND TRANSAXLE

Case and all internal parts, torque converter and converter housing, automatic transmission control module, transfer case and all internal parts, seals and gaskets, clutch cover and housing, A/T cooler, and electronic transmission controls.

62. Buyers, lessees, and other owners of the affected Class Vehicles were without access to the information concealed by Nissan as described herein, and therefore reasonably relied on Nissan's representations and warranties regarding the quality, durability, and other material characteristics of the Class Vehicles. Had these buyers and lessees known of the Engine Defect and the potential harm, they would have taken steps to avoid that harm and/or would have paid less for the Class Vehicles than the amounts they actually paid, or would not have purchased the Class Vehicles.

C. Complaints by Other Class Members Further Demonstrates Nissan's Knowledge of the Engine Defect

63. Plaintiff's experience is by no means an isolated or outlying occurrence. Indeed,

the internet is replete with examples of blogs and other websites where consumers have complained of the exact same Engine Defect within the Class Vehicles.²²

64. Class Vehicle owners have publicly complained to the United States government about the Engine Defect in Class Vehicles since the vehicle has been released. The Office of Defects Investigation (“ODI”) is an office within the National Highway Traffic Safety Administration (“NHTSA”). ODI conducts defect investigations and administers safety recalls to support the NHTSA’s mission to improve safety on the Nation’s highways.²³ All automobile manufacturers routinely monitor and analyze NHTSA complaints because this information is used in determining if a recall should be issued. Thus, Nissan has knowledge of any and all NHTSA complaints.

65. The following is just a small sampling of the many complaints submitted to ODI by Class Vehicle owners/lessees. These publicly available complaints, filed as early as October 6, 2022, evidence Nissan’s prior knowledge of the Engine Defect, the negative experiences encountered by Class Members, and the financial burden this places on them.

October 6, 2022 NHTSA ID NUMBER: 11488158
Components: ENGINE AND ENGINE COOLING, FUEL SYSTEM, GASOLINE

NHTSA ID Number: 11488158

Incident Date June 1, 2022

Consumer Location BETHANY, OK

Vehicle Identification Number JN8AT3AA2MW****

Summary of Complaint

[2021] The contact owns a 2021 Nissan Rogue. The contact stated that the fueling system was leaking. There was an abnormal odor of fuel detected. While driving at

²² See, e.g.,

https://www.reddit.com/r/NissanRogue/comments/103hrms/nissan_rogue_gas_leak2023_rogue_engineering/ (last visited April 21, 2023).

²³ See <https://www-odi.nhtsa.dot.gov/recalls/recallprocess.cfm> (last visited Mar. 21, 2022).

Indeed, automobile manufacturers are required by law to monitor NHTSA complaints and report any potential safety defects to the United States government. See TREAD Act, Pub. L. No. 106-414, 114 Stat. 1800 (2000).

an undisclosed speed, the vehicle lunged forward and stalled but restarted. The alternator warning light was illuminated. The vehicle was taken to the local dealer but the vehicle was not diagnosed or repaired. The manufacturer was not contacted. The failure mileage was approximately 5,500.

December 9, 2022 NHTSA ID NUMBER: 11496829

Components: FUEL/PROPULSION SYSTEM

NHTSA ID Number: 11496829

Incident Date December 9, 2022

Consumer Location ROCHESTER HILLS, MI

Vehicle Identification Number 5N1BT3CB4NC****

Summary of Complaint

[2022] My car smells gasoline inside and outside. I brought the car to the service dealer but the service manager said that they cannot figure out where gas odor coming from. I am using my car in bringing my 2 kids to school and going to work. My kids are getting sick and I am afraid my car will cause fire.

December 23, 2022 NHTSA ID NUMBER: 11498633

Components: FUEL/PROPULSION SYSTEM

NHTSA ID Number: 11498633

Incident Date November 2, 2022

Consumer Location MILWAUKEE, WI

Vehicle Identification Number 5N1BT3BB6PC****

Summary of Complaint

[2021] When driving vehicle cabin will fill with a fuel odor which can make you nauseous. In order to prevent the vents need to be on recirculate which in turn fog up all the windows in the winter time. Also when vehicle is parked in garage it fills the garage with an extremely strong fuel odor. Has been to the dealer 3 times, 2 times they couldn't reproduce and the 3rd time they can't find the problem. Nissan is aware and has it under "engineering review" with multiple claims from other owners.

December 29, 2022 NHTSA ID NUMBER: 11499442

Components: FUEL/PROPULSION SYSTEM

NHTSA ID Number: 11499442

Incident Date December 5, 2022

Consumer Location PLYMOUTH, MN

Vehicle Identification Number JN8BT3DD5NW****

Summary of Complaint

[2022] For several weeks I have noticed strong smell of gasoline when my car is parked in my garage. Today, I called my Nissan dealer because I am very concerned. The service advisor informed me that they have received many similar complaints and Nissan is supposedly trying to identify and remedy the problem. He said my car is safe, but I am terribly concerned.

December 30, 2022 NHTSA ID NUMBER: 11499566

Components: FUEL SYSTEM, GASOLINE

NHTSA ID Number: 11499566

Incident Date November 15, 2022

Consumer Location Unknown

Vehicle Identification Number 5N1BT3CB5NC****

Summary of Complaint

[2022] The contact owns a 2022 Nissan Rogue. The contact stated while the vehicle was parked in the garage, he started to smell and abnormal fuel odor. The contact stated no warning light was illuminated. The contact took the vehicle to the local dealer but was unable to determine the cause of the failure. The vehicle was not repaired. The manufacturer had been informed of the failure. The failure mileage was approximately 3,000.

January 5, 2023 NHTSA ID NUMBER: 11500268

Components: FUEL SYSTEM, GASOLINE, ENGINE

NHTSA ID Number: 11500268

Incident Date December 1, 2022

Consumer Location FAYETTEVILLE, AR

Vehicle Identification Number JN8BT3DD7PW****

Summary of Complaint

The contact owns a 2023 Nissan Rogue. The contact stated there was an abnormal fuel odor inside and outside the vehicle. Upon inspecting the vehicle, the contact found no visible leaks coming from the vehicle. The vehicle was then taken to the dealer where the mechanic also could not detect any leaks coming from the vehicle. The manufacturer had been notified of the failure and provided a case number. The vehicle was not repaired. The failure mileage was approximately 2,000.

January 13, 2023 NHTSA ID NUMBER: 11501676

Components: ENGINE, FUEL/PROPULSION SYSTEM

NHTSA ID Number: 11501676

Incident Date December 1, 2022

Consumer Location FLUSHING, MI

Vehicle Identification Number JN8BT3CB3PW****

Summary of Complaint

[2023] Strong gas odor in cabin of vehicle emanating from air cleaner housing. Also strong gas smell outside of vehicle after and while driving. Smell is very strong and causes dizziness, nausea and headaches.

January 13, 2023 NHTSA ID NUMBER: 11501655

Components: FUEL/PROPULSION SYSTEM

NHTSA ID Number: 11501655

Incident Date December 9, 2022

Consumer Location SPOKANE, WA

Vehicle Identification Number 5N1BT3BB9NC****

Summary of Complaint

[2022] Vehicle has raw fuel smell, both outside and inside. Smell intensity varies, sometimes it is faint, sometimes it smells up the whole garage for days. When restarting the vehicle after having driven it, fuel smell comes into the cabin from the air vents. Took to dealer multiple times. The first time, the Service Advisor noted the strong fuel smell. Subsequent visits to the dealer had faint fuel smell that was hard to detect over the typical odors in a repair shop. Opened a case with Nissan, and they sent a tech, but no resolution. Requested a re-purchase, and Nissan denied it. Nissan states this 1.5L engine is under Engineering Review, but they do not know if or when they will figure out a repair. This vehicle is an extreme health hazard with the exposure to hydrocarbon vapors, and is not safe to drive as an engine fire could result from the gas vapors. Issue started a month ago at 1100 miles.

[January 14, 2023 NHTSA ID NUMBER: 11501807](#)

[Components: FUEL/PROPULSION SYSTEM](#)

NHTSA ID Number: 11501807

Incident Date December 7, 2022

Consumer Location SAN DIEGO, CA

Vehicle Identification Number JN8BT3BA8NW****

Summary of Complaint

[2022] There is a strong smell of gasoline a few minutes after parking the vehicle in my enclosed garage. The smell is strongest on the drivers side, near base of the windshield and along the left side of the hood. This problem occurs every time I drive the vehicle more than 20 mins and then park it in an enclosed garage. 10 mins after parking it, the garage smells like spilled gasoline. I took the vehicle at 2,200 miles to a dealer and they stated that they were unable to duplicate the problem. They asked me to return the vehicle at 5,000 miles if I still had the problem.

[January 15, 2023 NHTSA ID NUMBER: 11501824](#)

[Components: FUEL/PROPULSION SYSTEM](#)

NHTSA ID Number: 11501824

Incident Date October 1, 2022

Consumer Location CHICAGO, IL

Vehicle Identification Number 5N1BT3BB3NC****

Summary of Complaint

[2022] For roughly the last three months, several times I have smelled fuel or gas in the interior cabin. Mostly at startup for first time during morning. But also when starting car after use earlier in the day. The smell dissipates after 10 minutes or so. Especially if I roll down windows to let in fresh air. Please let me know how address because dealer will not see issue as it does not occur with a defined pattern that I recognize. I did notice that when the gas tank was near empty the smell was very strong - and I was driving car for several minutes before the odor started. This issue is not healthy for breathing and I'm worried about it getting worse and becoming a safety issue.

[January 16, 2023 NHTSA ID NUMBER: 11502021](#)

Components: FUEL/PROPULSION SYSTEM

NHTSA ID Number: 11502021

Incident Date January 14, 2023

Consumer Location HORSEHEADS, NY

Vehicle Identification Number JN8BT3DD5NW****

Summary of Complaint

[2022] There is a strong unburied fuel smell on occasion. The dealer says that they are waiting for Nissan engineering to provide a repair and that it would be ok to drive.

January 17, 2023 NHTSA ID NUMBER: 11502157

Components: UNKNOWN OR OTHER

NHTSA ID Number: 11502157

Incident Date January 4, 2023

Consumer Location RED CREEK, NY

Vehicle Identification Number 5N1BT3BBXNC****

Summary of Complaint

[2022] After 9 months of owning this car. When I drive for 20 or so miles and turn the vehicle off for a short period then restart I smell gas and fumes make me sick and my eyes water at times. The dealer found nothing wrong. Nissan corporate got involved after I emailed them. Their engineering tech confirmed it was happening.

January 18, 2023 NHTSA ID NUMBER: 11502315

Components: ENGINE, FUEL/PROPULSION SYSTEM

NHTSA ID Number: 11502315

Incident Date January 18, 2023

Consumer Location MOLALLA, OR

Vehicle Identification Number 5N1BT3CB6NC****

Summary of Complaint

[2022] My Vehicle has 3,700 miles on it and i have smelled a very intense fuel smell in the cabin of the vehicle at least 6 times mostly when the interior fan is not set to recirculate the air, i took the vehicle to my local nissan service center and they could find no issues but said this is a complaint that others have also made. I am concerned that there could be a fire from the fumes that are being released.

January 19, 2023 NHTSA ID NUMBER: 11502725

Components: SUSPENSION, ENGINE

NHTSA ID Number: 11502725

Incident Date December 14, 2022

Consumer Location CORALVILLE, IA

Vehicle Identification Number JN8BT3CB2PW****

Summary of Complaint

[2023] First issue: After starting the vehicle there can be a smell of gasoline in the passenger cabin for a little bit. Also after parking vehicle in garage and turning off engine, the garage smells of gas and remains overnight, it is not exhaust fumes. Sometimes it seems to be worse after driving in reverse. There is no sign of a liquid

leak on the undercarriage or on the floor. Happens whether the gas tank is full or near empty. Vehicle is only 2 months since purchase. Second issue: The rear of the vehicle jerks sideways, usually toward the passenger side, when going over pavement joints, cracks or bumps. It is worse at highway speeds, but happens around town also. The rear of the vehicle doesn't seem to track straight when bumped. Took the vehicle to the dealer to check alignment and they said it was within specification and made no adjustments. The tire inflation is proper per the door jam. On some roads in bad weather it is a very uncomfortable feeling and feels like loss of control.

January 20, 2023 NHTSA ID NUMBER: 11502732

Components: FUEL/PROPULSION SYSTEM

NHTSA ID Number: 11502732

Incident Date January 19, 2023

Consumer Location WENONA, IL

Vehicle Identification Number 5N1BT3BB5NC****

Summary of Complaint

[2022] Gas smell after driving. Dealer replaced EVAP canister valve but still fills my garage with smell

January 23, 2023 NHTSA ID NUMBER: 11503291

Components: ENGINE, FUEL/PROPULSION SYSTEM

NHTSA ID Number: 11503291

Incident Date December 19, 2022

Consumer Location APPLETON, WI

Vehicle Identification Number 5N1BT3BB6PC****

Summary of Complaint

After about two months of driving our 2023 Nissan Rogue SV, a fuel odor emerged from the car. The odor is detected constantly in the car's interior and exterior. The fuel odor is so intense that we are concerned about the safety of parking the vehicle in our garage; we must park it outside. Due to the intensity of the fuel odor, we have purchased a fire extinguisher, as we are afraid of a car fire in the event of an accident/collision. Additionally, we are very concerned about our exposure to the gas fumes, and the health risk it may be causing. The dealership we bought the vehicle from evaluated the car, and informed us that the issue was that gas was sprayed accidentally on the hood liner during production. The dealership replaced the hood liner; however, upon returning the vehicle home the same day, the fuel odor persisted with the same intensity, and it did not fix the problem. The problem occurs after driving the vehicle, and the technician, who did the repair, must not have driven the vehicle.

January 23, 2023 NHTSA ID NUMBER: 11503128

Components: UNKNOWN OR OTHER

NHTSA ID Number: 11503128

Incident Date October 24, 2022

Consumer Location WILLOUGHBY HILLS, OH

Vehicle Identification Number 5N1BT3BB8PC****

Summary of Complaint

Fuel smell from engine compartment that enters cabin if heat turned on. Took to dealer, nothing showed up on computer. Unable to see leak, or evidence of fuel leak. Started about 2 months ago. Was reported to Nissan who states that it's under engineering review. Fuel smell lingers for a couple hrs after parked in garage. Concern for health exposure to fumes and potential engine fire hazard. No check engine warning lamps.

[January 26, 2023 NHTSA ID NUMBER: 11503767](#)

[Components: FUEL/PROPULSION SYSTEM](#)

NHTSA ID Number: 11503767

Incident Date January 18, 2023

Consumer Location FREETOWN, MA

Vehicle Identification Number JN8BT3DD0PW****

Summary of Complaint

[2023] After about the 3k miles mark, I started noticing a raw gas smell on the interior of the cabin when driving the vehicle. I also notice this gas smell when my vehicle is parked in my garage, with the engine off. I brought it to my local Nissan dealer, and they confirmed that it is a known issue 3 other 2023 Rogue customers have reported to this dealership. They did a visual inspection for leaks, and ran a computer diagnostic but nothing was found. At this point they informed me that corporate Nissan is aware of the issue and until they find the root cause of the problem, and issue a recall there is nothing my dealer can do.

[January 28, 2023 NHTSA ID NUMBER: 11504244](#)

[Components: UNKNOWN OR OTHER](#)

NHTSA ID Number: 11504244

Incident Date January 28, 2023

Consumer Location Unknown

Vehicle Identification Number 5N1BT3BB0PC****

Summary of Complaint

[2023] Smell of gas after driving

[January 30, 2023 NHTSA ID NUMBER: 11504489](#)

[Components: UNKNOWN OR OTHER, ENGINE, FUEL/PROPULSION SYSTEM](#)

NHTSA ID Number: 11504489

Incident Date October 1, 2022

Consumer Location CAROL STREAM, IL

Vehicle Identification Number 5N1BT3CB5NC****

Summary of Complaint

Gas fumes from engine compartment – after the car has been driven 20-30 mins enough to heat up the engine and then parked (turned off) for 10-15 minutes a strong smell of gasoline is detected, you can smell it either by sniffing in the front grill or if you start it and use the outdoor air circulation in the cabin it will come

through the vents. There are enough fumes to fill a 1 car garage in 30 mins with a thick odor of gasoline. The fumes are nauseating and cause headaches. My salesman at Hawk Nissan suggested changing gas to a top tier brand so I starting using Mobile but no help with the fume issue. After speaking with a service manager at Woodfield Nissan, he said that he's had a few cars come in recently with the same problem. Nothing is showing up mechanically so they chalked it up to a "break-in period" and/or possibly a coating used in manufacturing. Brought it back to Woodfield Nissan a couple weeks later stating the oil dipstick has a strong smell of gasoline same smell I get in the cabin and around the car. He found nothing unusual with the oil smell. I took it into Hawk Nissan Oct 2022 with 800 miles now with 2943 miles still having the issue. Not sure if this is affecting my MPG but I'm only getting 18-20 MPG mix of city & highway driving. Recently I'm seeing a lot of the same complaints with the 2023 models.

[January 31, 2023 NHTSA ID NUMBER: 11504729](#)

[Components: UNKNOWN OR OTHER, FUEL/PROPULSION SYSTEM](#)

NHTSA ID Number: 11504729

Incident Date January 23, 2023

Consumer Location Unknown

Vehicle Identification Number 5N1BT3AB9PC****

Summary of Complaint

This is my 2nd 2023 Nissan Rogue. The first one was purchase in October 2022 Around Thanksgiving 2022 we started smelling gas inside the car and outside the car. After the dealer confirmed the smell and told us there was no fix at the time, we left car at dealership and took a loaner, several weeks later the dealer said there is still no fix. We went to dealer and bought another 2023 Nissan Rogue at approximately 800 miles we started smelling the fumes in the cab and outside the vehicle

[February 3, 2023 NHTSA ID NUMBER: 11505455](#)

[Components: ENGINE, FUEL/PROPULSION SYSTEM](#)

NHTSA ID Number: 11505455

Incident Date December 26, 2022

Consumer Location CARY, IL

Vehicle Identification Number JN8BT3BB6PW****

Summary of Complaint

There is a constant strong fuel odor coming from the car, especially when it is parked inside the garage. It is most noticeable under the front hood as well as inside the cabin. The car has been inspected by the Nissan dealer and they have not found any leaks. They did confirm that this is a known concern, which is under engineering review and the dealership is working with a specialist to address this. They have also informed us the smell is caused by colder temperatures as more fuel needs to be injected than normal and thus causing the strong odor. However, the smell is constant even in warm temperatures. Also, a Nissan engineer has confirmed that this is caused by a design flaw, which only appears on cars with a turbo.

[February 3, 2023 NHTSA ID NUMBER: 11505449](#)

[Components: FUEL/PROPULSION SYSTEM](#)

NHTSA ID Number: 11505449

Incident Date January 2, 2023

Consumer Location WAUKON, IA

Vehicle Identification Number 5N1BT3ABXPC****

Summary of Complaint

[2023] Vehicle smells of strong gas smell in the cab and around the vehicle. Smell is so strong it makes you feel light headed and gives you a headache. This is a huge health concern for me and my family. When parking in the garage it smells so strong that you have to then park it outside so you do not have a fire hazard in the garage. Took it to the dealership to have diagnosed and was told that Nissan is aware of the issue and it is under engineering review but there is nothing they can do at this time. I then reached out to Nissan consumer affairs and they denied a buy back and told me that it is under engineering review but they do not have a fix for it. If they do not have a fix they should buy it back. This is a huge safety and health concern for me and my family.

[February 4, 2023 NHTSA ID NUMBER: 11505610](#)

[Components: FUEL/PROPULSION SYSTEM](#)

NHTSA ID Number: 11505610

Incident Date December 15, 2022

Consumer Location IDAHO FALLS, ID

Vehicle Identification Number JN8BT3BB3NW****

Summary of Complaint

We bought our 2022 Rogue in September 2022, it now has around 5300 miles on it. In December, we noticed that every time we drive it, the inside of the car fills with gas fumes. The fumes are so strong that it gives us extreme headaches, dizziness and nausea. When we park the Rogue in our garage, it creates a strong gas smell. We are concerned that it could explode or cause a fire. The vehicle was taken to Ron Sayer Nissan in Idaho Falls, Idaho on February 4, 2023 for diagnosis. The service manager, [XXX], informed us after examining the vehicle that he did not know what is causing the strong gasoline odor. The dealership did nothing to repair the vehicle and the problem continues. INFORMATION Redacted PURSUANT TO THE FREEDOM OF INFORMATION ACT (FOIA), 5 U.S.C. 552(B)(6).

[February 6, 2023 NHTSA ID NUMBER: 11505819](#)

[Components: UNKNOWN OR OTHER](#)

NHTSA ID Number: 11505819

Incident Date January 13, 2023

Consumer Location MACY, IN

Vehicle Identification Number 5N1BT3AB1PC****

Summary of Complaint

The smell of gas is so strong inside and outside of the cabin of the vehicle, that it is causing health issues. Nissan told me to put the car on air circulation as a temporary fix, but it is not working. My entire body is shaky and I'm suffering from migraines and nausea.

[February 7, 2023 NHTSA ID NUMBER: 11506004](#)

[Components: FUEL SYSTEM, GASOLINE](#)

NHTSA ID Number: 11506004

Incident Date August 1, 2022

Consumer Location ROUND LAKE BEACH, IL

Vehicle Identification Number JN8BT3BB1PW****

Summary of Complaint

The contact owns a 2023 Nissan Rogue. The contact stated that while operating the vehicle, there was an abnormal fuel odor inside the cabin of the vehicle. Additionally, while parked in the garage, the fuel odor was also present outside the vehicle. Upon inspection, no leaks were found. The vehicle was taken to the local dealer who was able to confirm the fuel odor but was unable to identify the cause of the odor. There were no repairs performed. The manufacturer was notified of the failure. The failure mileage was 500.

[February 9, 2023 NHTSA ID NUMBER: 11506346](#)

[Components: FUEL/PROPULSION SYSTEM](#)

NHTSA ID Number: 11506346

Incident Date February 7, 2023

Consumer Location NEW BEDFORD, MA

Vehicle Identification Number JN8BT3BB8PW****

Summary of Complaint

Good morning - I will be contacting the dealer today. I have a 2023 Nissan Rogue and there is a strong smell of gas in the cabin. I haven't purchased gasoline so it isn't that. It is coming from under the hood. My eyes burn I have a sore throat and am nauseous and dizzy. I looked it up online to troubleshoot and apparently it is a known issue however there isn't a recall. I've tried opening windows, closing them, recirculating the air nothing helps. Even after the car has sat for 8-9 hours it still smells inside and outside the car - edit I just called the dealer and they are backed up until next week. As far as the mph question, I can smell it when driving and parked.

[February 10, 2023 NHTSA ID NUMBER: 11506596](#)

[Components: UNKNOWN OR OTHER](#)

NHTSA ID Number: 11506596

Incident Date February 1, 2023

Consumer Location FISHERS, IN

Vehicle Identification Number 5N1BT3BB8PC****

Summary of Complaint

When I park my 2023 Nissan Rogue in the garage, the garage fills with a strong gas smell. This happens about 50% of the time. There are no performance issues or

warning lights involved. I took it to the dealership for assessment yesterday. They did not find evidence of a leak. They said Nissan is aware of this and is investigating and that there is no danger at this time. I believe this does create a health and safety risk to myself and my family and possibly to my home. They also reported that Nissan suggests this issue could be due to winterized gas. This response does not indicate that Nissan accepts responsibility or cares to solve this problem.

[February 13, 2023 NHTSA ID NUMBER: 11507010](#)

[Components: ENGINE, FUEL/PROPULSION SYSTEM](#)

NHTSA ID Number: 11507010

Incident Date January 13, 2023

Consumer Location CHANHASSEN, MN

Vehicle Identification Number JN8BT3DD6PW****

Summary of Complaint

[2023] Known issue, fuel smell inside cabin after initial start up and after parking in garage. Fuel/exhaust smells are persistent while initially driving off as well, significant safety risk as we are not certain where this is emanating (or originating) from. This is a health hazard and could potentially lead to engine fire, etc.

[February 13, 2023 NHTSA ID NUMBER: 11507075](#)

[Components: ENGINE, FUEL/PROPULSION SYSTEM](#)

NHTSA ID Number: 11507075

Incident Date October 24, 2022

Consumer Location ABILENE, KS

Vehicle Identification Number JN8BT3BA2NW****

Summary of Complaint

[2022] There is a strong smell of gasoline in the garage after I park my Rogue in it. We can smell it in the house. There is also the strong smell of gasoline in the cab when the car is idling, like when waiting in line or at a stop sign. This is not exhaust, it's fuel. I've had it checked once already during an oil change and am taking it back again tomorrow. This can't be safe to my health. Am also afraid it will set my house down on fire. Please help.

[February 14, 2023 NHTSA ID NUMBER: 11507262](#)

[Components: UNKNOWN OR OTHER](#)

NHTSA ID Number: 11507262

Incident Date September 6, 2022

Consumer Location VALLEY FALLS, NY

Vehicle Identification Number 5N1BT3CBXNC****

Summary of Complaint

[2022] Unknown Very strong gas smell inside the vehicle and outside the vehicle and under hood. This started with less the 4000 miles on it and it is just over 6200 miles at this time. I brought it to local nissan dealer lia nissan of Saratoga and was advised they can not find anything wrong with it and they can not do anything without a recall. So I am driving a vehicle around with excessive gas smell inside and out. This seems dangerous to me. I did express my concern to both the

dealership and nissan themselves and they still refuse to do anything. I asked what happens if I am in an accident and my car starts on fire or if I am driving and my car starts on fire. The service recep. Said well it looks like you will have a law suit. So don't think they realize this is not good. Breathing in gas is a health issue and this should be addressed and should not be ignored. These vehicles had gas issues the year prior so why isn't this a concern for nissan. This is a new vehicle smelling gas is a hazard and puts myself, my family and people driving around me at risk. Please consider reviewing this further.

[February 15, 2023 NHTSA ID NUMBER: 11507480](#)

[Components: FUEL/PROPULSION SYSTEM](#)

NHTSA ID Number: 11507480

Incident Date February 15, 2023

Consumer Location CARY, IL

Vehicle Identification Number JN8BT3BB6PW****

Summary of Complaint

I purchased a brand new 2023 Nissan Rogue. I can smell fuel when the car is in park. It is not exhaust either. It is fuel!!! The smell of fuel spreads into the house. We have health issues and are concerned about this problem. This is serious. We are also concerned that this could be a fire hazard as well.

[February 16, 2023 NHTSA ID NUMBER: 11507700](#)

[Components: FUEL SYSTEM, GASOLINE](#)

NHTSA ID Number: 11507700

Incident Date September 26, 2022

Consumer Location HUGO, MN

Vehicle Identification Number JN8BT3BBXNW****

Summary of Complaint

I purchased my new 2022 Nissan Rogue a few months ago. I do not drive a whole lot seeing as I am working from home. Yet I have noticed on many occasions that after going out and running my errands, I come home and park in my garage and my garage smells of very strong gas fumes. Yesterday I brought my car in to the Nissan Dealership for its first oil change and the service attendant asked me how I was liking it. So, I brought it up to him about the strong gas smell in my garage after driving car. He informed me that this is not the first time that they have heard this. He said they are researching at this time but have not been able to locate the issue. He stated that they were thinking it was the winter gas and I said no way. If gas was the issue, why is it only the 2022 Nissan Rogue having an issue with the gas. Makes no sense. He stated there is no recall on it yet seeing as they cannot figure out the issue, but I will most likely be seeing a recall once they figure it out. They noted on receipt that "they were unable to duplicate concern, no fuel leak at fuel lines or tank. Nissan is aware of issue and seeking a remedy, customer will be notified." This is very scary to me, it is a strong smell, like there is raw gas leaking. I am afraid of it catching fire or just the fact of inhaling these fumes are not safe. This is a huge safety hazard and Nissan does not seem to care. Are they waiting for something horrible to happen before they take this seriously?

[February 19, 2023 NHTSA ID NUMBER: 11508056](#)

[Components: UNKNOWN OR OTHER](#)

NHTSA ID Number: 11508056

Incident Date January 2, 2023

Consumer Location OMAHA, NE

Vehicle Identification Number 5N1BT3BBXPC****

Summary of Complaint

The cabin of the vehicle fills with a gasoline odor when driven. When I park the vehicle in the garage (with engine OFF), the garage fills with a gasoline odor. I have experienced nausea and headaches with the smell. My oldest child has complained about the smell and making his head hurt. It is very concerning that my ATTACHED garage fills with gasoline odor and could continue into my residence. I am now forced to park my vehicle outside and can not have my two children in the vehicle. I took the vehicle back to the dealership and they initially claimed it was an O Ring around the gasoline tank. They replaced it and the issue still continued. They then advised that Nissan is aware of this issue but does not have a fix at this time. There are cases around the country with this issue. I am now using a loaner vehicle from the dealership until Nissan finds a fix. There is approximately 5,300 miles on the vehicle. There are no warning messages on the dash. This problem started at the beginning of January.

[February 24, 2023 NHTSA ID NUMBER: 11508998](#)

[Components: UNKNOWN OR OTHER, ENGINE, FUEL/PROPULSION SYSTEM](#)

NHTSA ID Number: 11508998

Incident Date October 10, 2022

Consumer Location Unknown

Vehicle Identification Number JN8BT3CB0PW****

Summary of Complaint

Strong smell of raw gasoline coming from the front of the vehicle after driving and while driving. If parked in garage entire garage has strong odor that penetrates into attached house. Very hazardous to health and emissions.

[February 25, 2023 NHTSA ID NUMBER: 11509070](#)

[Components: ENGINE, FUEL/PROPULSION SYSTEM](#)

NHTSA ID Number: 11509070

Incident Date November 1, 2022

Consumer Location Unknown

Vehicle Identification Number 5N1BT3BBXNC****

Summary of Complaint

[2022] There is a very strong gas smell in the cabin coming through the vents. Opening windows doesn't help as it is outside the vehicle as well. It smells like gasoline is actually covering the vehicle. Causes nausea & ightheadedness. Worried for health from breathing in the fumes and fire risk. Nissan service changed evap

canister and problem persists. I bought the vehicle brand new and is an unresolved issue.

[February 26, 2023 NHTSA ID NUMBER: 11509202](#)

[Components: ENGINE, FUEL/PROPULSION SYSTEM](#)

NHTSA ID Number: 11509202

Incident Date January 2, 2023

Consumer Location Unknown

Vehicle Identification Number 5N1BT3BB9PC****

Summary of Complaint

[2023] After 3000 miles on my car I noticed a gasoline smell in my garage after driving it. Now I have 5000 miles and the gasoline smell is so strong I have to park it outside my garage since my garage is attached to my house and the smell enters my house and makes me feel nauseous and gives me a headache. I have made an appointment with 2 Nissan dealers who state it is a known problem but there is nothing they can do about it at this time and are waiting to hear from Nissan. There are no warning lights on in my car.

[February 28, 2023 NHTSA ID NUMBER: 11509497](#)

[Components: ENGINE, FUEL/PROPULSION SYSTEM](#)

NHTSA ID Number: 11509497

Incident Date January 18, 2023

Consumer Location Unknown

Vehicle Identification Number JN8BT3DD7PW****

Summary of Complaint

[2023] SMELLS strongly of GAS. Location of smell is strongest on driver side closest to windshield under the hood. Vehicle is currently with 2280 miles. Purchased in December of 2022. Smell began mid January 2023 with mileage approximately at 1700.

[March 1, 2023 NHTSA ID NUMBER: 11509730](#)

[Components: FUEL/PROPULSION SYSTEM](#)

NHTSA ID Number: 11509730

Incident Date February 10, 2023

Consumer Location Unknown

Vehicle Identification Number 5N1BT3AB0PC****

Summary of Complaint

[2023] The new Nissan Rogue I just bought has gasoline smell that comes into the cabin from the Engine compartment when driving at low speeds. I took the car to the dealer where I was told that Nissan was aware of the gas smell and are looking into a fix. I also called Nissan Corp. and was told that they are aware of the problem and that the gas fumes are not a danger. Also I was told that this is happening to some of the late 2022's and the 2023's. Nissan needs to get this problem fixed ASAP. This Is a safety and a health issue. Please Investigate. Thanks

[March 2, 2023 NHTSA ID NUMBER: 11509925](#)

Components: FUEL/PROPULSION SYSTEM

NHTSA ID Number: 11509925

Incident Date November 1, 2022

Consumer Location Unknown

Vehicle Identification Number JN8BT3BB5NW****

Summary of Complaint

[2022] The vehicle has a very strong raw gasoline smell after driving. The smell is very noticeable both outside and inside of the cabin. This condition is becoming more frequent the more it's driven. The odor is strong enough to make the driver lightheaded and nauseous. The vehicle was purchased new. Dealership is unable to diagnose and Nissan corporate continuously refers this issue back to the dealership.

March 3, 2023 NHTSA ID NUMBER: 11510014

Components: FUEL/PROPULSION SYSTEM

NHTSA ID Number: 11510014

Incident Date February 28, 2023

Consumer Location Unknown

Vehicle Identification Number 5N1BT3BB2PC****

Summary of Complaint

[2023] Fuel smell in garage on a regular basis. No gasoline or gas powered equipment is stored in the garage. The gasoline smell is noticeable when vehicle is warm after driving. Smell was first noticed soon after purchase of vehicle. We didn't really worry about it at first. But it continues to persist. Dealership is blaming it on spillage from gas pumps. The vehicle is currently at half tank, no noticeable smell from filler area. Smell is not noticeable when vehicle is cold. Gasoline odors are dangerous and possibly explosive. No warning lamps are visible or any symptoms shown by vehicle. Vehicle is being taken to dealership on 3/4/23 to be checked out.

March 3, 2023 NHTSA ID NUMBER: 11509983

Components: FUEL/PROPULSION SYSTEM

NHTSA ID Number: 11509983

Incident Date October 24, 2022

Consumer Location Unknown

Vehicle Identification Number 5N1BT3BB8PC****

Summary of Complaint

[2023] Fuel smell continues from engine compartment. Specifically after parked in garage and it is localized to the windshield gutter on drivers side. Started 2-3 months ago. Was reported to Nissan who state that it is under engineering review and there is no fix at this time. When heater turned on, fuel smell gets into cabin. Concern for health exposure to fumes as well as potential fire hazard. Check engine warning light does not come on. Only 3000 miles on the car. Bought in September 2022.

March 9, 2023 NHTSA ID NUMBER: 11510926

Components: ENGINE, FUEL/PROPULSION SYSTEM

NHTSA ID Number: 11510926
Incident Date January 18, 2023
Consumer Location Unknown
Vehicle Identification Number JN8BT3DDXPW****

Summary of Complaint

[2023] After driving the car and parking it in the garage we notice a "raw gasoline" smell. If we are driving and idle at a stop sign the heater (heating the interior) picks up the gasoline smell and the fumes come inside the car. We have to open the windows to air it out once moving. The problem appears to be getting worse, meaning the smell is getting stronger. We have contacted Nissan and they gave me a case number #48234302, but no progress. The dealer says Nissan is working on the issue, but there is no fix. I have call both Nissan and the dealer since 1-18-2023, but for the most part no one will respond anymore. We find the smell a health concern.

[March 13, 2023 NHTSA ID NUMBER: 11511676](#)
[Components: ENGINE, FUEL/PROPULSION SYSTEM](#)

NHTSA ID Number: 11511676
Incident Date March 13, 2023
Consumer Location Unknown
Vehicle Identification Number JN8BT3CB1PW****

Summary of Complaint

Strong smell of gasoline in our garage, coming from the 2023 Nissan Rogue everytime we park the car. Fumes/vapors fill the garage, and then into the house.

[March 14, 2023 NHTSA ID NUMBER: 11511851](#)
[Components: FUEL/PROPULSION SYSTEM](#)

NHTSA ID Number: 11511851
Incident Date March 11, 2023
Consumer Location Unknown
Vehicle Identification Number 5N1BT3BB0NC****

Summary of Complaint

I smell gas inside my car. I take the car to the dealer they check everything but they say they can't fix it. They know about the leak and they say it's hopping on the Nissan's 2022 and 2023 . They know about the problem with those cars but they still sell sold them to the people.

[March 21, 2023 NHTSA ID NUMBER: 11513040](#)
[Components: ENGINE, FUEL/PROPULSION SYSTEM](#)

NHTSA ID Number: 11513040
Incident Date October 20, 2022
Consumer Location Unknown
Vehicle Identification Number 5N1BT3CB5NC****

Summary of Complaint

[2022] Vehicle smells of strong gas smell in the cab and around the vehicle. Smell is so strong it makes you feel light headed and gives you a headache.

This is a huge health concern for me. When parking in the garage it smells so strong that you have to then park it outside for a couple hours after driving so you do not have a fire hazard in the garage. Took it to the dealership to have diagnosed and was told that they can't find a problem however now I'm see reports that Nissan is aware of the issue and it is under engineering review but there is nothing they can do at this time. I then reached out to Nissan consumer affairs which was absolutely no help at all. This is a huge safety and health concern for me.

March 23, 2023 NHTSA ID NUMBER: 11513524

Components: UNKNOWN OR OTHER

NHTSA ID Number: 11513524

Incident Date December 9, 2022

Consumer Location Unknown

Vehicle Identification Number 5N1BT3CB4NC****

Summary of Complaint

[2022] Smell of gasoline inside my car while driving and when parked inside my garage .Brought to the dealer and said to me that the are many car owners of the same model who are complaining of the same problem but they cannot fixed it at this time and will just call me if they will find solution of the problem but until now the dealer haven't call me back.The problem is getting worse and it is a significant fire hazard in my car and also in my garage.

March 25, 2023 NHTSA ID NUMBER: 11513772

Components: UNKNOWN OR OTHER

NHTSA ID Number: 11513772

Incident Date March 25, 2023

Consumer Location Unknown

Vehicle Identification Number JN8BT3CB7PW****

Summary of Complaint

[2023] When parked and off, or sitting in idle a major smell of gasoline is spewing out of the hvac system in the car. It makes me nauseous and major headaches. This can't be safe to drive. This has always been an issue. I've only owned the vehicle since December.

March 30, 2023 NHTSA ID NUMBER: 11514692

Components: FUEL/PROPULSION SYSTEM

NHTSA ID Number: 11514692

Incident Date January 1, 2023

Consumer Location Unknown

Vehicle Identification Number 5N1BT3BB4PC****

Summary of Complaint

[2023] For months now, inside the cabin and outside of the car smell like raw fuel. I have taken it to Nissan and they were unable to find anything wrong. There are times I have to roll down the window because the smell is so strong. This is an almost everyday occurrence.

[April 7, 2023 NHTSA ID NUMBER: 11516032](#)

[Components: UNKNOWN OR OTHER, ENGINE](#)

NHTSA ID Number: 11516032

Incident Date March 7, 2023

Consumer Location Unknown

Vehicle Identification Number 5N1BT3BB3PC****

Summary of Complaint

[2023] The smell of gas fumes was inside and outside of the car. I took a CO2 blood test and the CO2 levels came back high. The dealership said a recall was coming out soon. The vehicle supposedly was looked over by the dealership service manager. This began shortly after I bought the vehicle. Didn't know it was an issue until I saw a lawsuit against the company regarding this matter.

[April 7, 2023 NHTSA ID NUMBER: 11515891](#)

[Components: FUEL/PROPULSION SYSTEM](#)

NHTSA ID Number: 11515891

Incident Date April 6, 2023

Consumer Location Unknown

Vehicle Identification Number 5N1BT3CB9PC****

Summary of Complaint

[2023] Once I park my car in garage after a while my whole garage smells like gas. This started the end of March being an issue. The car has 1212 miles Tonight I backed it out of garage because the smell was so strong. I do have an appointment with Billion Dealership on April 15th hoping to resolve the issue.

[April 8, 2023 NHTSA ID NUMBER: 11516075](#)

[Components: FUEL/PROPULSION SYSTEM](#)

NHTSA ID Number: 11516075

Incident Date April 7, 2023

Consumer Location Unknown

Vehicle Identification Number 5N1BT3CB9PC****

Summary of Complaint

[2023] Another night of leaving my new car outside instead of in garage because of the gas smell. I believe it is very dangerous and I have family staying with me. I'm scared it could start a fire.

CLASS ACTION ALLEGATIONS

66. Plaintiff brings this action on behalf of himself, and on behalf of the following nationwide class pursuant to Fed. R. Civ. P. 23(a), 23(b)(2), and/or 23(b)(3). Specifically, the nationwide class consists of the following:

Nationwide Class:

All persons or entities in United States who are current or former owners and/or lessees of

a Class Vehicle (the “Nationwide Class”).

67. In the alternative to the Nationwide Class, and pursuant to Fed. R. Civ. P. 23(c)(5), Plaintiff seeks to represent the following state class only in the event that the Court declines to certify the Nationwide Class above:

New Jersey Class:

All persons or entities in New Jersey who are current or former owners and/or lessees of a Class Vehicle (the “New Jersey Class”).

68. Together, the Nationwide Class and New Jersey Class shall be collectively referred to herein as the “Class” or “Classes.” Excluded from the Classes are Defendants, their affiliates, employees, officers and directors, persons or entities that purchased the Class Vehicles for resale, and the Judge(s) assigned to this case. Plaintiff reserves the right to modify, change or expand the Class definitions.

69. Numerosity: Upon information and belief, the Classes are so numerous that joinder of all members is impracticable. While the exact number and identities of individual members of the Classes are unknown at this time, such information being in the sole possession of Nissan and obtainable by Plaintiff only through the discovery process, Plaintiff believes that tens of thousands of Class Vehicles have been sold and leased in each of the states that are the subject of the Classes.

70. Existence and Predominance of Common Questions of Fact and Law: Common questions of law and fact exist as to all members of the Classes. These questions predominate over the questions affecting individual Class members. These common legal and factual questions include, but are not limited to:

- a. whether the engines in the Class Vehicles are predisposed to premature failure;
- b. whether the engines in the Class Vehicles contain a manufacturing defect;
- c. whether the defective PCV system is common to all or some of the Class Vehicles;

- d. whether the Engine Defect causes engines to fail in the Class Vehicles;
- e. whether Defendant knowingly failed to disclose the existence and cause of the Engine Defect in Class Vehicles;
- f. whether Defendant's conduct violates the consumer protection statutes alleged herein;
- g. whether, as a result of Defendant's omissions and/or misrepresentations of material facts related to the Engine Defect, Plaintiff and members of the Classes have suffered ascertainable loss of monies and/or property and/or value;
- h. whether, as a result of Defendant's omissions and/or misrepresentations of material facts related to the Engine Defect, Plaintiff and members of the Class have suffered an increased cost of maintenance related to the Class Vehicles; and
- i. whether Plaintiff and Class members are entitled to monetary damages and/or other remedies and, if so, the nature of any such relief.

71. Typicality: All of the Plaintiff's claims are typical of the claims of the Classes since Plaintiff purchased a Class Vehicle with the Defect, as did each member of the Classes. Furthermore, Plaintiff and all members of the Classes sustained monetary and economic injuries including, but not limited to, ascertainable loss arising out of Nissan's wrongful conduct. Plaintiff is advancing the same claims and legal theories on behalf of himself and all absent Class members.

72. Adequacy: Plaintiff is an adequate representative because his interests do not conflict with the interests of the Classes he seeks to represent, he has retained counsel competent and highly experienced in complex class action litigation, and he intends to prosecute this action vigorously. The interests of the Classes will be fairly and adequately protected by Plaintiff and his counsel.

73. Superiority: A class action is superior to all other available means of fair and efficient adjudication of the claims of Plaintiff and members of the Classes. The injury suffered by each individual Class member is relatively small in comparison to the burden and expense of individual prosecution of the complex and extensive litigation necessitated by Nissan's conduct. It would be virtually impossible for members of the Classes to individually and effectively redress the wrongs done to them. Even if the members of the Classes could afford such individual litigation, the court system could not. Individualized litigation presents a potential for inconsistent or contradictory judgments. Individualized litigation also increases the delay and expense to all parties, and to the court system, presented by the complex legal and factual issues of the case. By contrast, the class action device presents far fewer management difficulties, and provides the benefits of single adjudication, economy of scale, and comprehensive supervision by a single court. Upon information and belief, members of the Classes can be readily identified and notified based on, *inter alia*, Nissan's vehicle identification numbers (VINs), warranty claims, registration records, and the database of complaints.

74. Injunctive Relief: Pursuant to Fed. R. Civ. P. 23(b)(2), Nissan has acted or refused to act on grounds generally applicable to the Classes, thereby making appropriate final injunctive relief, corresponding declaratory relief, or final equitable relief with respect to the class as a whole.

LEGAL CAUSES OF ACTION

COUNT I

VIOLATION OF MAGNUSON-MOSS WARRANTY ACT,

15 U.S.C. § 2301, *et seq.* ("MMWA")

(On Behalf of the Nationwide Class or, Alternatively, the State Sub-Classes)

75. Plaintiff hereby incorporates by reference the allegations contained in the preceding paragraphs of this Complaint.

76. The MMWA provides a private right of action by purchasers of consumer products against retailers who, *inter alia*, fail to comply with the terms of an implied or written warranty. 15 U.S.C. § 2310(d)(1). As alleged herein, Defendant has failed to comply with its implied warranty of merchantability with regard to the Class Vehicles.

77. The Class Vehicles are consumer products, as that term is defined in 15 U.S.C. § 2301(1).

78. Plaintiff and each member of the Class are consumers, as that term is defined in 15 U.S.C. § 2301(3).

79. Defendant is a supplier and warrantor, as those terms are defined in 15 U.S.C. §§ 2301(4)-(5).

80. The MMWA provides a cause of action for breach of warranty or other violations of the Act. 15 U.S.C. § 2310(d)(1). Defendant breached the implied warranty of merchantability for the Class Vehicles, as alleged herein, which it cannot disclaim under the MMWA, 15 U.S.C. § 2308(a)(1), by failing to provide merchantable goods. Plaintiff has suffered damages as a result of Defendant's breach of the implied warranty of merchantability as set forth herein. 15 U.S.C. §§ 2310(d)(1)-(2).

81. Defendant was provided notice of the claims raised by Plaintiff and was afforded a reasonable opportunity to cure. Defendant failed to cure in that it has not offered a repair to Plaintiff and class members who own the Class Vehicles for the Defect. Until Plaintiff's representative capacity is determined, notice and opportunity to cure through Plaintiff, and on behalf of the Class, can be provided under 15 U.S.C. § 2310(e).

82. Defendant's acts and omissions in violation of the MMWA are "[u]nfair methods of competition in or affecting commerce, and unfair or deceptive acts or practices in or affecting

commerce,” and they are unlawful. 15 U.S.C. § 2310(b); 15 U.S.C. § 45(a)(1).

83. Plaintiff and the members of the Class have suffered, and are entitled to recover, damages as a result of Defendant’s breach of express and/or implied warranties and violations of the MMWA.

84. Plaintiff also seeks an award of costs and expenses, including attorneys’ fees, under the MMWA to prevailing consumers in connection with the commencement and prosecution of this action. 15 U.S.C. § 2310(d)(2). Plaintiff and the prospective Class intend to seek such an award, including expert witness costs and other recoverable costs, as prevailing consumers at the conclusion of this lawsuit.

COUNT II
BREACH OF EXPRESS WARRANTY
(On Behalf of the Nationwide Class or, Alternatively, the State Sub-Classes)

85. Plaintiff and the Classes incorporate by reference each preceding and succeeding paragraph as though fully set forth at length herein.

86. Defendant expressly warranted that the Class Vehicles were of high quality and, at a minimum, would actually work properly. Defendant also expressly warranted that it would repair and/or replace defects in material and/or workmanship free of charge that occurred during the New Vehicle Limited Warranty, Powertrain Limited Warranty and certified pre-owned (“CPO”) warranty periods.

87. Defendant breached these warranties by selling to Plaintiff and class members the Class Vehicles with known engine problems, which are not of high quality, and which fail prematurely and/or fail to function properly.

88. As a result of the Defendant’s actions, Plaintiff and class members have suffered economic damages including but not limited to costly repairs, loss of vehicle use, substantial loss

in value and resale value of the vehicles, and other related damage.

89. Defendant's attempt to disclaim or limit these express warranties vis-à-vis consumers is unconscionable and unenforceable under the circumstances here. Specifically, Defendant's warranty limitations are unenforceable because it knowingly sold a defective product without informing consumers about the manufacturing and/or material defect. Furthermore, Defendant continues to charge Class members for repairing the defective engines – if it repairs them at all -- when in fact such repairs are actually necessitated because of Defendant's defective product.

90. The time limits contained in Defendant's warranty periods were also unconscionable and inadequate to protect Plaintiff and members of the Class. Among other things, Plaintiff and class members had no meaningful choice in determining these time limitations, the terms of which unreasonably favored Defendant. A gross disparity in bargaining power existed between Nissan and Class members, and Defendant knew or should have known that the Class Vehicles were defective at the time of sale and would fail well before their useful lives.

91. Plaintiff and class members have complied with all obligations under the warranties, or otherwise have been excused from performance of said obligations as a result of Defendant's conduct described herein.

COUNT III
BREACH OF IMPLIED WARRANTY
(On Behalf of the Nationwide Class or, Alternatively, the State Sub-Classes)

92. Plaintiff and the Class incorporate by reference each preceding and succeeding paragraph as though fully set forth at length herein.

93. A warranty that the Class Vehicles were in merchantable condition is implied by law.

94. These Class Vehicles, when sold and at all times thereafter, were not in merchantable condition and are not fit for the ordinary purpose for which cars are used. Specifically, the Class Vehicles are inherently defective in that there are defects in the Class Vehicles' engines, which are not of high quality, and which fail prematurely and/or fail to function properly.

95. Defendant was provided notice of these issues by numerous informal and formal complaints filed against it, including the instant Complaint, and by numerous individual letters and communications sent by Plaintiff and other Class members.

96. As a direct and proximate result of Defendant's breach of the warranties of merchantability, Plaintiff and the other Class members have been damaged in an amount to be proven at trial.

COUNT IV
COMMON LAW FRAUD/FRAUDULENT CONCEALMENT
(On Behalf of the Nationwide Class or, Alternatively, the State Sub-Classes)

97. Plaintiff and the Class incorporate by reference each preceding and succeeding paragraph as though fully set forth at length herein.

98. Defendant made material omissions concerning a presently existing or past fact. For example, Defendant did not fully and truthfully disclose to its customers the defective nature of the Class Vehicles' engines, which was not readily discoverable until after the Vehicles were purchased. As a result, Plaintiff and the other Class members were fraudulently induced to lease and/or purchase the Class Vehicles with the said Engine Defect and all of the resultant problems.

99. These omissions were made by Defendant with knowledge of their falsity, and with the intent that Plaintiff and class members rely upon them.

100. Plaintiff and class members reasonably relied on these omissions and suffered

damages as a result.

COUNT V
UNJUST ENRICHMENT
(On Behalf of the Nationwide Class or, Alternatively, the State Sub-Classes)

101. Plaintiff and the Class incorporate the foregoing allegations. This count is pled in the alternative to the contract-based claims.

102. Plaintiff and members of the Class conferred a benefit on Defendant.

103. Defendant had knowledge that this benefit was conferred upon it.

104. Defendant has been and continues to be unjustly enriched at the expense of Plaintiff, and its retention of this benefit under the circumstances would be inequitable.

COUNT VI
VIOLATIONS OF THE NEW JERSEY
CONSUMER FRAUD ACT, N.J. Stat. Ann. §§ 56:8-1, *et seq.*
(On Behalf of the New Jersey Class)

105. Plaintiff incorporates by reference all allegations of the preceding paragraphs as though fully set forth herein.

106. Plaintiff brings this claim on behalf of the New Jersey Class under the New Jersey Consumer Fraud Act, N.J. Stat. Ann. §§ 56:8-1, *et seq.* (“NJCFA”).

107. Plaintiff, the New Jersey Class members, and Defendant are persons within the meaning of N.J. Stat. Ann. § 56-8-1(d).

108. Defendant is engaged in the “sale” of “merchandise” within the meaning of N.J. Stat. Ann. § 56:8-1(c).

109. Defendant’s advertisements described herein are “advertisements” within the meaning of N.J. Stat. Ann. § 56:8-1(a).

110. The NJCFA prohibits “any unconscionable commercial practice, deception, fraud, false pretense, false promise, misrepresentation, or the knowing concealment, suppression or

omission of any material fact with the intent that others rely upon such concealment, suppression or omission, in connection with the sale or advertisement of any merchandise.” N.J. Stat. Ann. § 56:8-2.

111. Defendant employed unconscionable commercial practices in its advertisement and sale of the Class Vehicles, which are defective. Defendant’s practices in connection with the advertisement and sale of the Class Vehicles were unscrupulous and demonstrate a lack of honesty and fair dealing.

112. Defendant engaged in fraudulent and deceptive trade practices, in violation of the NJCFA, by misrepresenting and knowingly concealing the existence of the Defect. Such information was material to a reasonable consumer because, among other things, the Defect can cause exposure to the inhalation of fuel vapors that pose a grave health risk and can distract the vehicle driver and cause a collision, a risk of fire, and forces consumers to incur additional repair expenses, diminishes the value of Class Vehicles, and represents an unreasonable safety risk to consumers.

113. Defendant’s material misrepresentations and knowing omissions are highly likely to mislead the public and induce consumers to make misinformed purchases.

114. Defendant owed a duty to disclose material facts about the defective nature of the Class Vehicles because: (1) Defendant had exclusive or superior knowledge of the Defect in the Class Vehicles; (2) Defendant knew that Plaintiff and New Jersey Class members were unaware of the Defect in the Class Vehicles; (3) Defendant understood the true facts regarding the Defect in the Class Vehicles, including that they are defective and prone to strong fuel smells and vapors in vehicle cabins and in the vicinity of their exteriors, which would be important to reasonable prospective buyers of the Class Vehicles; and (4) Defendant made representations regarding the

quality and functionality of the Class Vehicles that were misleading, deceptive, and incomplete without the disclosure of the true facts regarding the Defect in the Class Vehicles.

115. The misrepresentations and knowing material omissions described above were uniform across the New Jersey Class. All of the advertising, promotional materials, and manuals contained the same material misrepresentations and knowing omissions.

116. The misrepresentations and knowing material omissions were intended to induce Plaintiff and New Jersey Class members to purchase Class Vehicles. Plaintiff and New Jersey Class members would not have purchased a Class Vehicle, or would have paid less for them, in the absence of Defendant's misrepresentations and knowing material omissions.

117. Plaintiff and New Jersey Class members suffered ascertainable loss as a direct and proximate result of Defendant's unconscionable and deceptive acts and practices. Among other injures, Plaintiff and New Jersey Class members overpaid for their Class Vehicles, and their Class Vehicles suffered a diminution in value.

118. As permitted under N.J. Stat. Ann. § 56:8-19, Plaintiff and New Jersey Class members seek trebled damages, appropriate injunctive relief, and reasonable attorney's fees.

PRAYER FOR RELIEF

WHEREFORE, Plaintiff, on behalf of himself and members of the Classes, respectfully requests that this Court:

- A. determine that the claims alleged herein may be maintained as a class action under Rule 23 of the Federal Rules of Civil Procedure, and issue an order certifying the Classes as defined above;
- B. appoint Plaintiff as the representative of the Classes and his counsel as Class counsel;

- C. award all actual, general, special, incidental, statutory, and consequential damages to which Plaintiff and Class members are entitled;
- D. award pre-judgment and post-judgment interest on such monetary relief;
- E. grant appropriate injunctive and/or declaratory relief, including, without limitation, an order that requires Nissan to repair, recall, and/or replace the Class Vehicles and to extend the applicable warranties to a reasonable period of time, or, at a minimum, to provide Plaintiff and Class members with appropriate curative notice regarding the existence and cause of the manufacturing defect;
- F. award reasonable attorney's fees and costs; and
- G. grant such further relief that this Court deems appropriate.

Dated: April 21, 2023

Respectfully submitted,

By: /s/ J. Gerard Stranch, IV
J. Gerard Stranch, IV, BPR No. 23045
Michael G. Stewart, BPR No. 016920
STRANCH, JENNINGS & GARVEY, PLLC
223 Rosa L. Parks Avenue, Suite 200
Nashville, Tennessee 37203
T: (615) 254-8801
F: (615) 255-5419
gstranch@stranchlaw.com
mstewart@stranchlaw.com

Joseph G. Sauder (*pro hac vice* to be filed)
Matthew D. Schelkopf (*pro hac vice* to be filed)
Joseph B. Kenney (*pro hac vice* to be filed)
Mark B. DeSanto (*pro hac vice* to be filed)
SAUDER SCHELKOPF
1109 Lancaster Avenue
Berwyn, PA 19312
Tel: (610) 200-0581
Facsimile: (610) 421-1326
jgs@sstriallawyers.com
mds@sstriallawyers.com
jbk@sstriallawyers.com
mbd@sstriallawyers.com